

WELDING STUDS



ATS
bet on us

UNI EN ISO 9001:2015Reg.3023-A Quality System Certified Company



Index

Index 2

1. Welding studs for capacitor discharge stud welding	6
1.1 Technical Information	6
Dimensions.....	6
Surface protection	6
Threads	6
Stud flange	6
Welding Pip.....	6
Accessories for stud welding guns	6
1.2 Threaded stud (type PT according to DIN EN ISO 13918).....	7
1.3 Internally threaded stud (type IT according to DIN EN ISO 13918).....	8
1.4 Non-threaded stud (type UT acc. to DIN EN ISO 13918).....	9
1.5 Fir tree stud	10
1.6 Threaded stud with self-cleaning groove (self-tapping)	11
1.7 Threaded stud without flange	12
1.8 Threaded stud with reduced flange	13
1.9 Earth plug (Faston)	14
1.10 Double earth plug (Faston).....	14
1.11 Pin nail	15
1.12 Pin Nail Clip (Type R)	16
1.13 Clip (Type R, 11.5mm OD)	16
1.14 Plastic-coated pin nail clip (type W)	17
1.15 Pin nail with clip.....	18
1.16 Insulated pin nail with clip.....	19
1.17 Silicone cover cap.....	20
1.17.1 Silicone cover caps for threaded studs and non-threaded studs	20
1.17.2 Silicone cover caps for internally threaded studs.....	20
1.17.3 Silicone Cover Caps for Earth Plug (Faston)	20
1.17.4 Silicone Cover Caps for Double Earth Plug (Faston).....	20
Annex: Accessories and Wear Parts for Stud Welding Guns	21
2. Accessories and wear parts of stud welding guns	21
2.1 Threaded stud (PT type), internally threaded stud (IT type), non-threaded stud (UT type), fir tree stud, self-tapping groove stud, threaded stud without flange, threaded stud with reduced flange diameter.	21
2.2 Earth plug, double earth plug (Faston)	21
2.3 Pin nail	22
2.4 Pin Nail With Clip, Insulated Pin Nail With Clip	22
3. Welding studs for drawn arc welding with ceramic ferrule.....	23
3.1 Technical Information	23
Materials	23

Dimensions.....	24
Surface protection	24
Threads	24
Weld fillet	24
Stud Welding Gun Accessories.....	24
3.2 Shear connector (type SD1 and SD3 according to DIN EN ISO 13918).....	25
3.3 Threaded stud with reduced shaft (type RD according to DIN EN ISO 13918).....	27
3.4 Threaded stud with practically complete thread (type MD according to DIN EN ISO 13918, before: type MPF)	28
3.5 Threaded stud with partial thread (type PD acc.to DIN EN ISO 13918)	29
3.6 Threaded stud with full thread (type FD according to DIN EN ISO 13918).....	30
3.7 Internally threaded stud (type ID according to DIN EN ISO 13918)	31
3.8 Non-threaded stud (type UD according to DIN EN ISO 13918)	32
3.9 Bimetal threaded stud with practically complete thread (type MD-DUO, before: type MPF-DUO)	33
3.10 Bimetallic threaded stud with partial thread (type PD-DUO).....	33
3.11 Bimetallic threaded stud with reduced shaft (type RD-DUO).....	34
3.12 Bimetallic internally threaded stud (type ID-DUO)	34
3.13 Insulation pins and clips	35
3.13.1 Insulation pin (type ISMS).....	35
3.13.2 Insulation pic (type ISA).....	36
3.13.3 Insulation pin (type ISB).....	37
3.13.4 Bimetallic insulation pin (type VBS-MS).....	38
3.13.5 Bimetallic insulation pin (type VBS)	38
3.13.6 Insulation pin (type ISH)	39
3.13.7 Clip for insulation pin (type R).....	40
3.13.8 Clip with plastic cap for insulation pin (type W).....	41
3.14 Rectangular stud (type A)	42
3.15 Rectangular stud (type B)	43
3.16 Rectangular stud (type C)	44
3.17 Threaded collar stud (KRB type).....	45
3.18 Collar stud (KRS type)	46
3.19 Threaded stud (type M)	47
3.20 Threaded knock-off stud (type AB-MD, before: AB-MPF).....	48
3.21 Knock-off stud.....	48
3.22 Curved stud.....	48
3.23 J-bolt stud	49
3.24 Bent stud	49
3.25 Stepped stud.....	49
3.26 Locking stud.....	50
3.27 Cone stud.....	50

3.28	Flat ended stud.....	50
3.29	Anti-skid knock-off stud.....	51
3.30	Ball	51
3.31	Padded ring for shear connectors.....	52
3.32	Ceramic ferrules	53
1.32.1	Ceramic ferrule for shear connectors, internally threaded studs and non-threaded studs (type UF acc. to DIN EN ISO 13918).....	53
1.32.2	Ceramic ferrule for threaded studs with reduced shaft (type RF acc. to DIN EN ISO 13918).....	54
1.32.3	Ceramic ferrule for threaded studs with reduced shaft, flat form (type RF (flat form) acc. to DIN EN ISO 13918).....	54
1.32.4	Ceramic ferrule for threaded studs with reduced shaft (type KSR-F).....	55
1.32.5	Ceramic ferrule for threaded studs (type MF acc. to DIN EN ISO 13918, before: type KSP-F).....	55
1.32.6	Ceramic ferrule for threaded studs (type PF acc. to DIN EN ISO 13918).....	56
1.32.7	Ceramic ferrule for internally threaded studs and non-threaded studs (type KSN-F).....	56
1.32.8	Permanent ceramic ferrule for pin nails (type K).....	57
1.32.9	Ceramic ferrule for rectangular studs (type KF).....	57
3.32.10	Special ceramic ferrule (welding through the metal deck) for shear connectors (type DF according to DIN EN ISO 13918).....	58
3.32.11	Special ceramic ferrule (welding to vertical surfaces) for shear connector (HSG type).....	58
3.32.12	Special ceramic ferrule (welding into angles) for shear connectors (type IWKR).....	59
3.32.13	Special ceramic ferrule (welding onto angles) for shear connectors (type AWKR).....	59
3.32.14	Special ceramic ferrule (welding to convex surfaces) for shear connectors (type ABKR).....	60
3.33	Fixing accessories.....	61
3.33.1	Threaded plate.....	61
3.33.2	Disc nut.....	61
3.34	Silicone cover caps.....	62
3.34.1	Silicone cover caps for threaded studs and non-threaded studs.....	62
3.34.2	Silicone cover caps for internally threaded studs.....	62
4.	Welding studs for short cycle stud welding.....	63
4.1	Technical Information.....	63
	Materials.....	63
	Dimensions.....	63
	Surface protection.....	63
	Threads.....	63
	Stud Flange.....	63
	Weld Face.....	63
	Stud Welding Gun Accessories.....	63
4.2	Threaded stud (type PS acc. to DIN EN ISO 13918).....	64
4.3	Internally threaded stud (type IS acc. to DIN EN ISO 13918).....	65
4.4	Non-threaded stud (type US acc. to DIN EN ISO 13918).....	66
4.5	Fir tree stud.....	67

4.6	Threaded stud with self-cleaning groove (self-tapping)	68
4.7	Silicone cover caps	69
4.7.1	Silicone Cover Caps for Threaded Studs and Non-Threaded Studs	69
4.7.2	Silicone cover caps for internally threaded studs	69

1. Welding studs for capacitor discharge stud welding

1.1 Technical Information

Materials

We produce our welding studs from the following materials with excellent weldability:

Material group/strength class	Norm
Steel 4,8	ISO 898-1
A2-50, A2-70, A5-50, A5-70	ISO 3506-1
Group 22.3	ISO/TR 15608
Group 32	ISO/TR 15608

The material specifications are in accordance with DIN EN ISO 13918 and DIN EN ISO 14555. For welding studs from other materials, please send us your request or contact us.

On request, the material properties can be checked with an inspection document (test report, inspection certificate) in accordance with DIN EN 10204.

We are happy to inform you about the weldability of the different base materials and the welding parameters.

Dimensions

The dimensions of the weld studs are shown in the measurement tables (all dimensions are in mm). All standardised weld studs comply with DIN EN ISO 13918. Non-standardised weld studs are supplied in accordance with DIN EN ISO 13918. Special welding elements, not described, are supplied on request.

Dimensions not listed in the size tables are provided upon request.

Surface protection

As a rule, our welding studs made of 4.8 steel are supplied with an electrolytic copper plating of 4-8 μm (according to DIN EN ISO 4042) as corrosion protection. Other surface treatments are possible on request.

Threads

The stud threads are cold-rolled (tolerance limit 6g). For surface-treated pins, the 6h tolerance limit can be reached. On request, we supply studs with special threads.

Stud flange

The welding pins for discharging capacitors have a cold-formed flange. The diameter of the flange is always larger than the outer diameter of the welding element (see drawings and measurement tables below). The flange prevents the electric arc from sliding on the cylindrical part of the welding element and increases the welding area. This ensures a high strength of the welded joint.

On request, weld studs with flange sizes other than those listed and weld studs without flange can be supplied. However, the limited use of flangeless weld studs is recommended, depending on the requirements of the welded joint. Please contact us for this.

Welding Pip

Weld studs for capacitor discharge soldering have a cold-formed calibrated welding pip with tightly controlled length and diameter tolerances. At the welding pip, the welding process is started and the duration of the welding time is determined. Therefore, the exact size of the welding pip is decisive for achieving correct welding results.

Accessories for stud welding guns

Accessories for welding guns must be adapted to the welding element. The accessories to be used for the individual weld studs are given in chapter 2.1.

1.2 Threaded stud (type PT according to DIN EN ISO 13918)

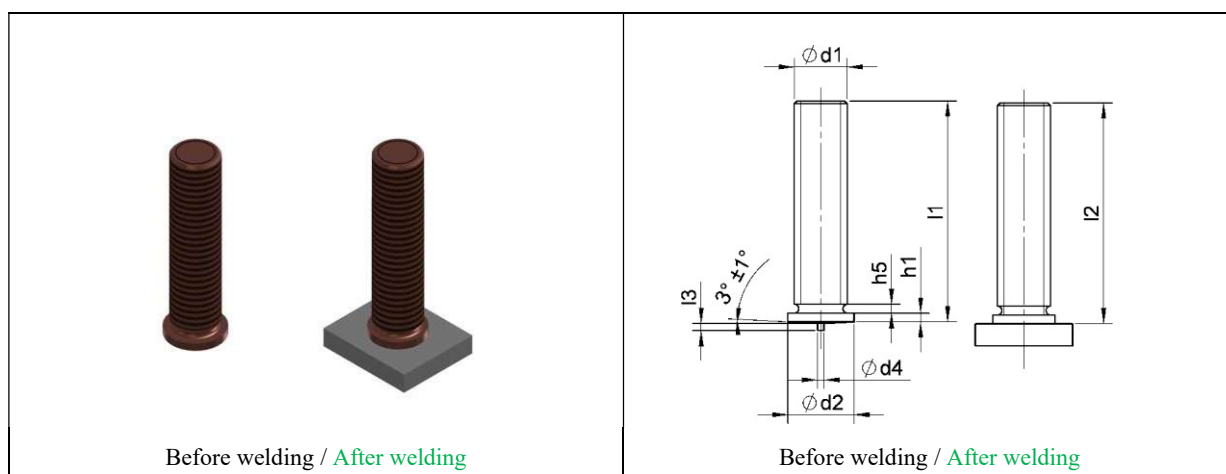

Dimensions								Material (item number)				
d1	l1 +0,6	d2 ±0,2	d4 ±0,08	l3 ±0,05	h5 max.	h1	l2	Steel 4.8 copper-plated	A2-50	A5-50	AlMg3	CuZn37
M3	6-30	4,5	0,6	0,55	0,6	0,7-1,4	≈ l1-0,3	ATS015 1103XXX	ATS015 1203XXX	On request	ATS140 03XXX	ATS130 03XXX
M4	6-40	5,5	0,65	0,55	0,6	0,7-1,4	≈ l1-0,3	ATS015 1104XXX	ATS015 1204XXX	On request	ATS140 04XXX	ATS130 04XXX
M5	6-45	6,5	0,75	0,8	1,0	0,7-1,4	≈ l1-0,3	ATS015 1105XXX	ATS015 1205XXX	On request	ATS140 05XXX	ATS130 05XXX
M6	8-60	7,5	0,75	0,8	1,0	0,7-1,4	≈ l1-0,3	ATS015 1106XXX	ATS015 1206XXX	On request	ATS140 06XXX	ATS130 06XXX
M8	10-60	9	0,75	0,85	1,5	0,8-1,4	≈ l1-0,3	ATS015 1108XXX	ATS015 1208XXX	On request	ATS140 08XXX	ATS130 08XXX
M10	12-60	10,7	0,75	0,75	3	1,2-1,6	≈ l1-0,3	ATS015 1110XXX	ATS015 12010XXX	On request	ATS140 10XXX	ATS130 10XXX

The article number **XXX** must be replaced by the respective length of the welding element l1 (e.g. 030 for 30 mm).

Explanations of the materials used can be found in chapter 1.1.

Sizes and materials not listed are available upon request.

1.3 Internally threaded stud (type IT according to DIN EN ISO 13918)

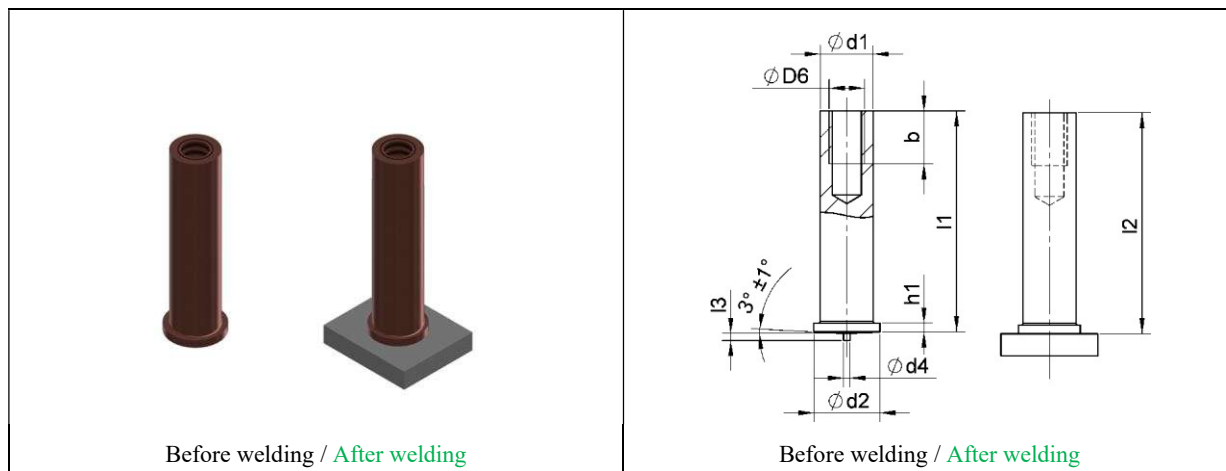

Dimensions									Material (item number)				
d1 ±0,1	l1 +0,6	D6	b min. +2P ¹	d2 ±0,2	d4 ±0,08	l3 ±0,05	h1	l2	Steel 4.8 copper- plated	A2-50	A5-50	AlMg3	CuZn37
5	6-30	M3	5 (4 ²)	6,5	0,75	0,8	0,7-1,4	≈ 11-0,3	ATS01531 35XXX	ATS01532 35XXX	On request	ATS01534 35XXX	ATS01533 35XXX
6	8-40	M4	6	7,5	0,75	0,8	0,7-1,4	≈ 11-0,3	ATS01531 46XXX	ATS01532 46XXX	On request	ATS01534 46XXX	ATS01533 46XXX
7,1	10-40	M5	7,5	9	0,75	0,85	0,8-1,4	≈ 11-0,3	ATS01531 57XXX	ATS01532 57XXX	On request	ATS01534 57XXX	ATS01533 57XXX
8	10-40	M6	7,5	9	0,75	0,85	0,8-1,4	≈ 11-0,3	ATS01531 68XXX	ATS01532 68XXX	On request	ATS01534 68XXX	On request

¹P = thread pitch according to DIN 13-1

²per < 8 mm

The article number **XXX** must be replaced by the respective length of the welding element l1 (e.g. 030 for 30 mm).

Explanations of the materials used can be found in chapter 1.1.

Sizes and materials not listed are available upon request.

1.4 Non-threaded stud (type UT acc. to DIN EN ISO 13918)

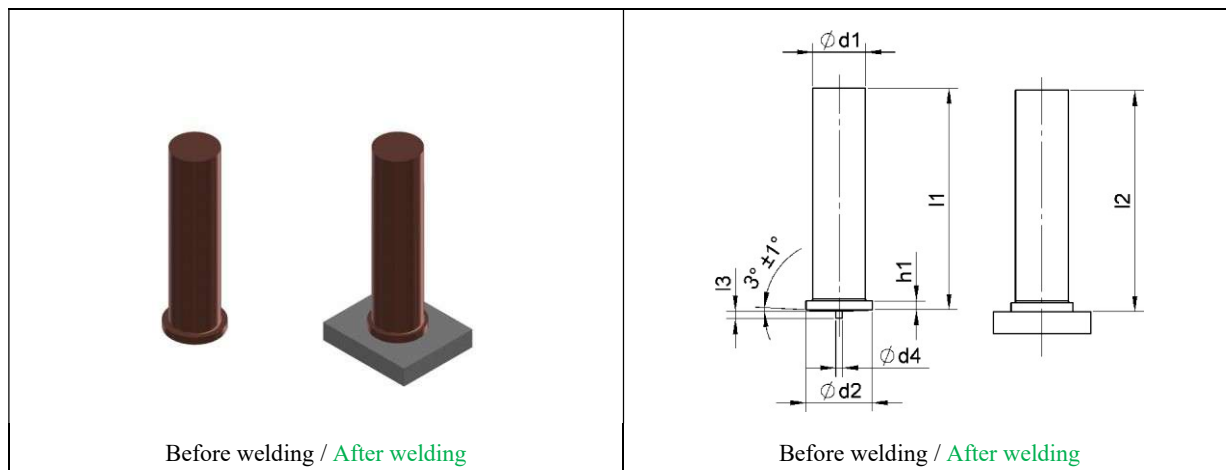

Dimensions							Material (item number)				
d1	l1	d2	d4	l3	h1	l2	Steel 4.8 copper-plated	A2-50	A5-50	AlMg3	CuZn37
±0,1	+0,6	±0,2	±0,08	±0,05							
3	6-30	4,5	0,6	0,55	0,7-1,4	≈ 11-0,3	ATS01521 03XXX	ATS01522 03XXX	On request	ATS01524 03XXX	ATS01523 03XXX
4	6-40	5,5	0,65	0,55	0,7-1,4	≈ 11-0,3	ATS01521 04XXX	ATS01522 04XXX	On request	ATS01524 04XXX	ATS01523 04XXX
5	6-45	6,5	0,75	0,8	0,7-1,4	≈ 11-0,3	ATS01521 05XXX	ATS01522 05XXX	On request	ATS01524 05XXX	ATS01523 05XXX
6	8-60	7,5	0,75	0,8	0,7-1,4	≈ 11-0,3	ATS01521 06XXX	ATS01522 06XXX	On request	ATS01524 06XXX	ATS01523 06XXX
7,1	10-60	9	0,75	0,85	0,8-1,4	≈ 11-0,3	ATS01521 07XXX	ATS01522 07XXX	On request	ATS01524 07XXX	ATS01523 07XXX
8	10-40	9	0,75	0,85	0,8-1,4	≈ 11-0,3	ATS01521 08XXX	ATS01522 08XXX	On request	On request	On request

The article number **XXX** must be replaced by the respective length of the welding element l1 (e.g. 030 for 30 mm).

Explanations of the materials used can be found in chapter 1.1.

Sizes and materials not listed are available upon request.

1.5 Fir tree stud

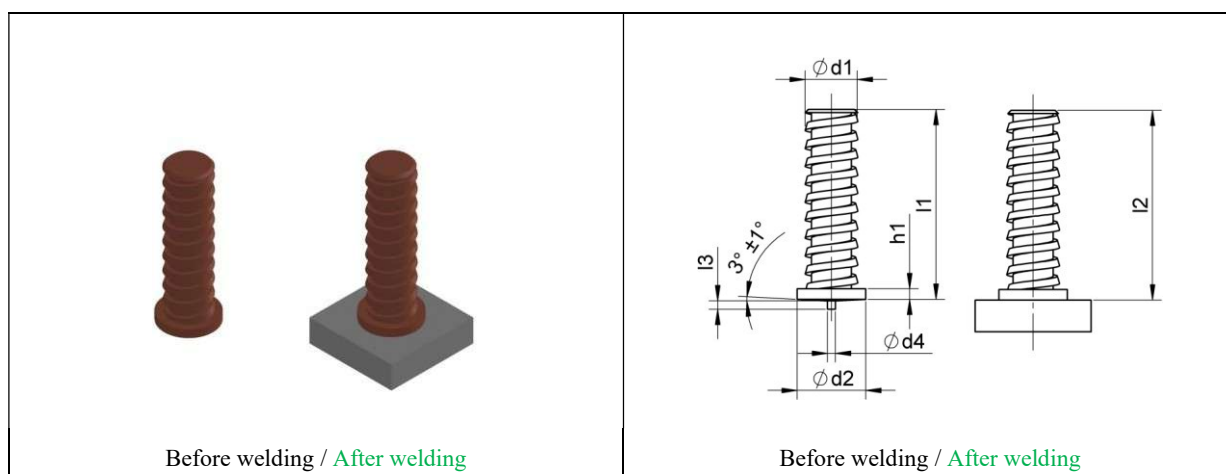

Dimensions							Material (item number)		
d1	l1 +0,6	d2 $\pm 0,2$	d4 $\pm 0,08$	l3 $\pm 0,05$	h1	l2	Steel 4.8 copper-plated	A2-50	AlMg3
5	9	6,5	0,75	0,8	0,7-1,4	$\approx 11-0,3$	ATS1015009	On request	On request
5	14,2	6,5	0,75	0,8	0,7-1,4	$\approx 11-0,3$	ATS1015014	On request	On request
5	18	6,5	0,75	0,8	0,7-1,4	$\approx 11-0,3$	ATS1015018	On request	On request
5	25	6,5	0,75	0,8	0,7-1,4	$\approx 11-0,3$	ATS1015025	On request	On request

Explanations of the materials used can be found in chapter 1.1.

Sizes and materials not listed are available upon request.

1.6 Threaded stud with self-cleaning groove (self-tapping)

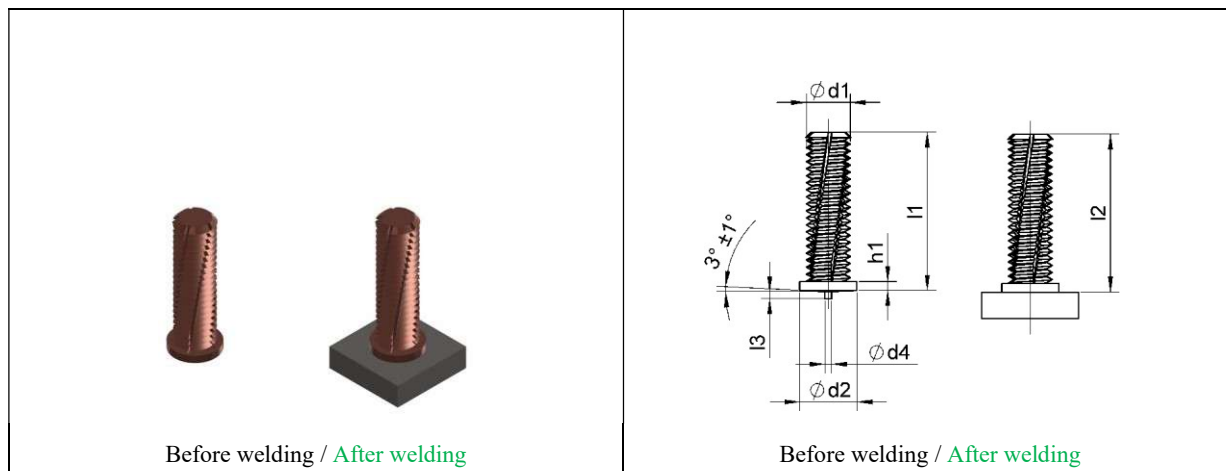

Dimensions							Material (item number)			
d1	l1 +0,6	d2 ±0,2	d4 ±0,08	l3 ±0,05	h1	l2	Steel 4.8 copper-plated	A2-50	AlMg3	CuZn37
M4	On request	5,5	0,65	0,55	0,7-1,4	≈ l1-0,3	ATS01511 04XXXAM	On request	On request	On request
M5	On request	6,5	0,75	0,8	0,7-1,4	≈ l1-0,3	ATS01511 05XXXAM	On request	On request	On request
M6	On request	7,5	0,75	0,8	0,7-1,4	≈ l1-0,3	ATS01511 06XXXAM	On request	On request	On request
M8	On request	9	0,75	0,85	0,8-1,4	≈ l1-0,3	ATS01511 08XXXAM	On request	On request	On request

The article number **XXX** must be replaced by the respective length of the welding element l1 (e.g. 030 for 30 mm).

Explanations of the materials used can be found in chapter 1.1.

Sizes and materials not listed are available upon request.

1.7 Threaded stud without flange

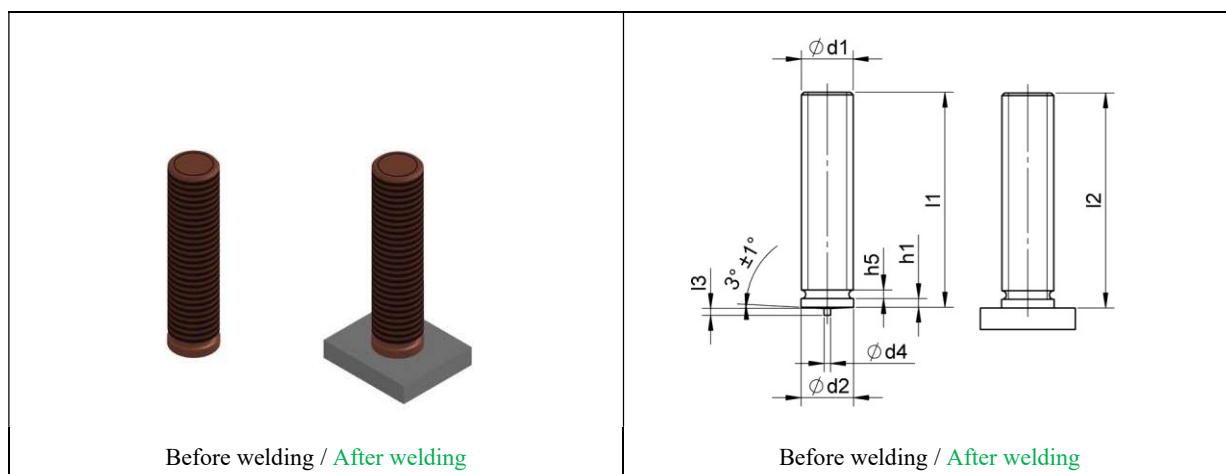

Dimensions								Material (item number)		
d1	l1	d2	d4	l3	h5	h1	l2	Steel 4.8 copper-plated	A2-50	A5-50
	+0,6	+0,1	±0,08	±0,05	max.					
M3	6-30	3	0,6	0,55	0,6	0,7-1,4	≈ l1-0,3	AlMg3 03XXXOFL	On request	On request
M4	6-40	4	0,65	0,55	0,6	0,7-1,4	≈ l1-0,3	On request	On request	On request
M5	6-45	5	0,75	0,8	1,0	0,7-1,4	≈ l1-0,3	On request	On request	On request
M6	8-60	6	0,75	0,8	1,0	0,7-1,4	≈ l1-0,3	On request	On request	On request
M8	10-60	8	0,75	0,85	1,5	0,8-1,4	≈ l1-0,3	On request	On request	On request
M10	12-60	10	0,75	0,75	3	1,2-1,6	≈ l1-0,3	On request	On request	On request

The article number **XXX** must be replaced by the respective length of the welding element l1 (e.g. 030 for 30 mm).

Explanations of the materials used can be found in chapter 1.1.

Sizes and materials not listed are available upon request.

1.8 Threaded stud with reduced flange

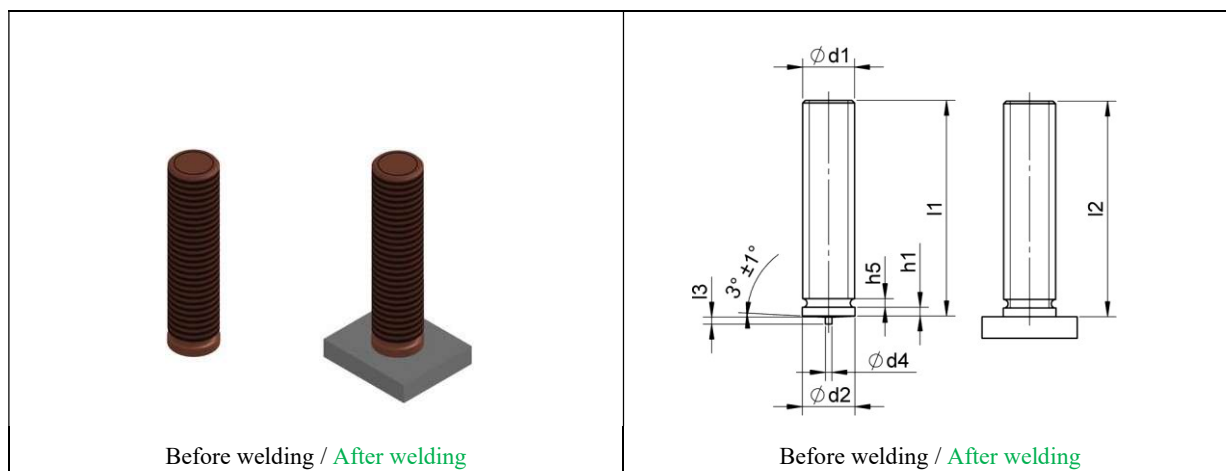

Dimensions								Material (item number)		
d1	l1 +0,6	d2 +0,3	d4 $\pm 0,08$	l3 $\pm 0,05$	h5 max.	h1	l2	Steel 4.8 copper-plated	A2-50	A5-50
M3	6-30	3,1	0,6	0,55	0,6	0,7-1,4	$\approx l1-0,3$	ATS01511 03XXXRFL	On request	On request
M4	6-40	4,1	0,65	0,55	0,6	0,7-1,4	$\approx l1-0,3$	On request	On request	On request
M5	6-45	5,1	0,75	0,8	1,0	0,7-1,4	$\approx l1-0,3$	On request	On request	On request
M6	8-60	6,1	0,75	0,8	1,0	0,7-1,4	$\approx l1-0,3$	On request	On request	On request
M8	10-60	8,1	0,75	0,85	1,5	0,8-1,4	$\approx l1-0,3$	On request	On request	On request
M10	12-60	10,1	0,75	0,75	3	1,2-1,6	$\approx l1-0,3$	On request	On request	On request

The article number **XXX** must be replaced by the respective length of the welding element l1 (e.g. 030 for 30 mm).

Explanations of the materials used can be found in chapter 1.1.

Sizes and materials not listed are available upon request.

1.9 Earth plug (Faston)

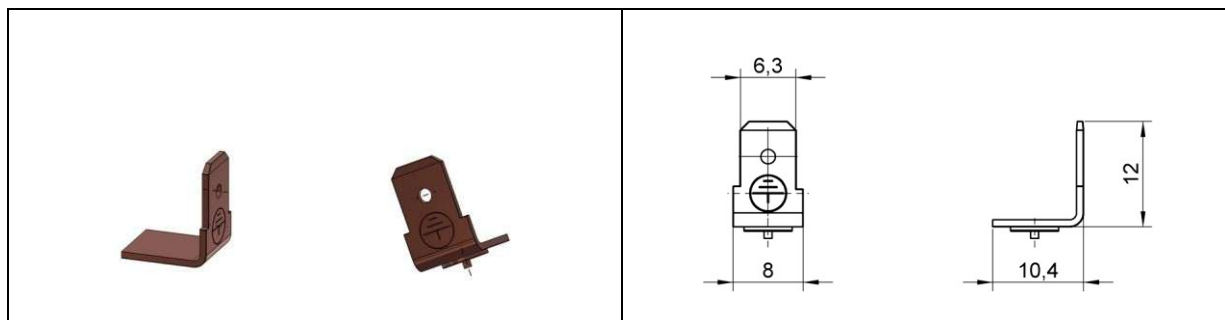

Material (item number)			
Steel copper-plated	A2-50	AlMg3	CuZn37
ATSSFS6,3FE37	ATS3020063	ATS3040063	ATS3030063

Explanations of the materials used can be found in chapter 1.1.

Sizes and materials not listed are available upon request.

1.10 Double earth plug (Faston)

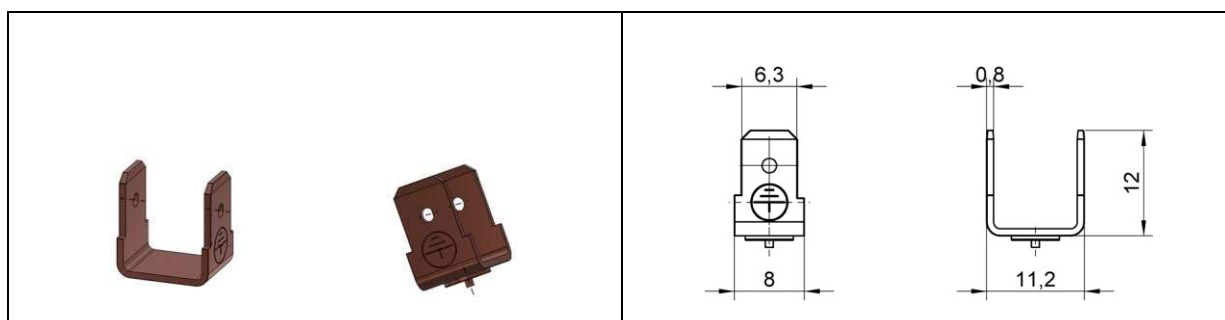

Materials (item number)			
Steel copper-plated	A2-50	AlMg3	CuZn37
ATSSFD6,3FE37	ATS3022063	ATS3044063	On request

Explanations of the materials used can be found in chapter 1.1.

Sizes and materials not listed are available upon request.

1.11 Pin nail

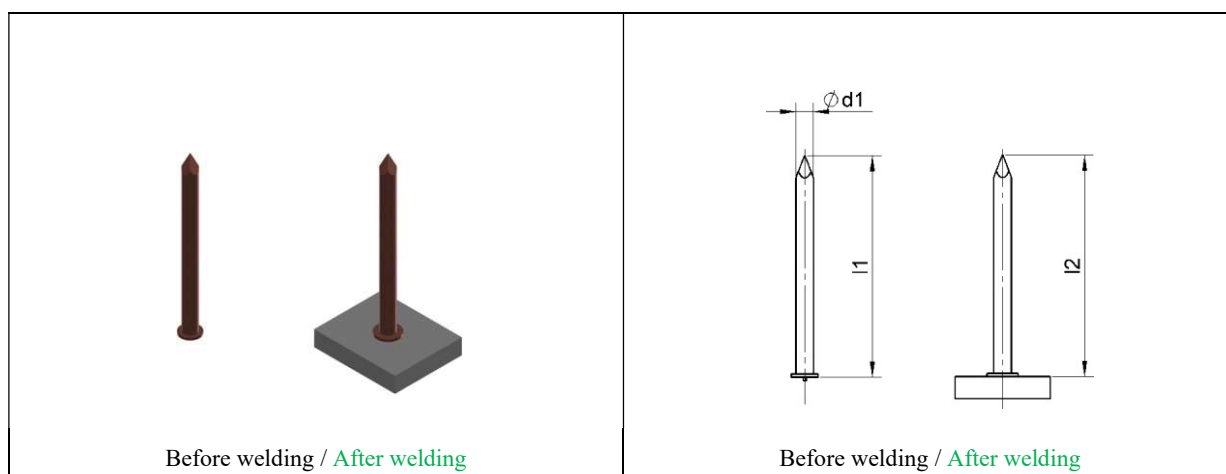

Dimensions			Materials (item number)		
d1	l1	l2	Steel 4.8 copper-plated	A2-50	AlMg3
$\pm 0,06$	$\pm 2,00$				
2	20-150	$\approx l1-0,3$	ATS4102XXX	ATS4202XXX	ATS4402XXX
3	20-150	$\approx l1-0,3$	ATS4103XXX	ATS4203XXX	ATS4403XXX

The article number **XXX** must be replaced by the respective length of the welding element l1 (e.g. 030 for 30 mm).

Explanations of the materials used can be found in chapter 1.1.

Sizes and materials not listed are available upon request.

1.12 Pin Nail Clip (Type R)

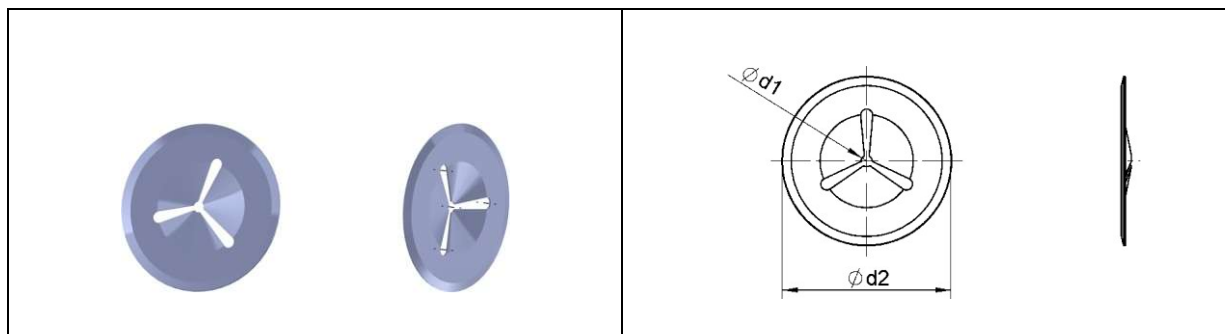

Dimensions		Materials (item number)	
d ₁	d ₂	Zinc-plated steel	1.4310
2	38	ATS4912002	ATS4922002
3	38	ATS4913003	ATS4923003
3	60	On request	On request

Sizes and materials not listed are available upon request.

1.13 Clip (Type R, 11.5mm OD)

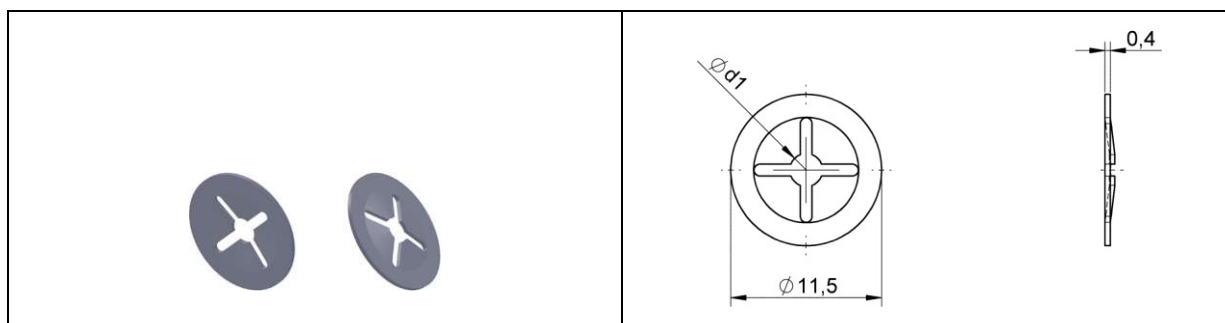

Dimensions	Materials (item number)
d ₁	Zinc-plated steel
3	On request
4	On request
5	On request

Sizes and materials not listed are available upon request.

1.14 Plastic-coated pin nail clip (type W)

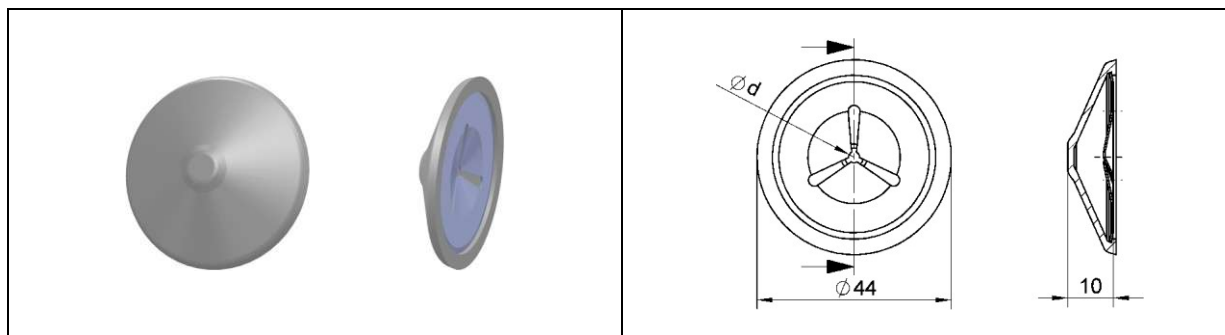

Dimensions	Material (item number)			
	Steel zinc-plated with plastic cap (white)	Steel zinc-plated with plastic cap (black)	1.4310 with plastic cap (white)	1.4310 with plastic cap (black)
d	On request	On request	On request	On request
2	On request	On request	On request	On request
3	ATS4953003	ATS4953003N	On request	ATS4963003N

Plastic cap: halogen-free, self-extinguishing

Sizes and materials not listed are available upon request.

1.15 Pin nail with clip

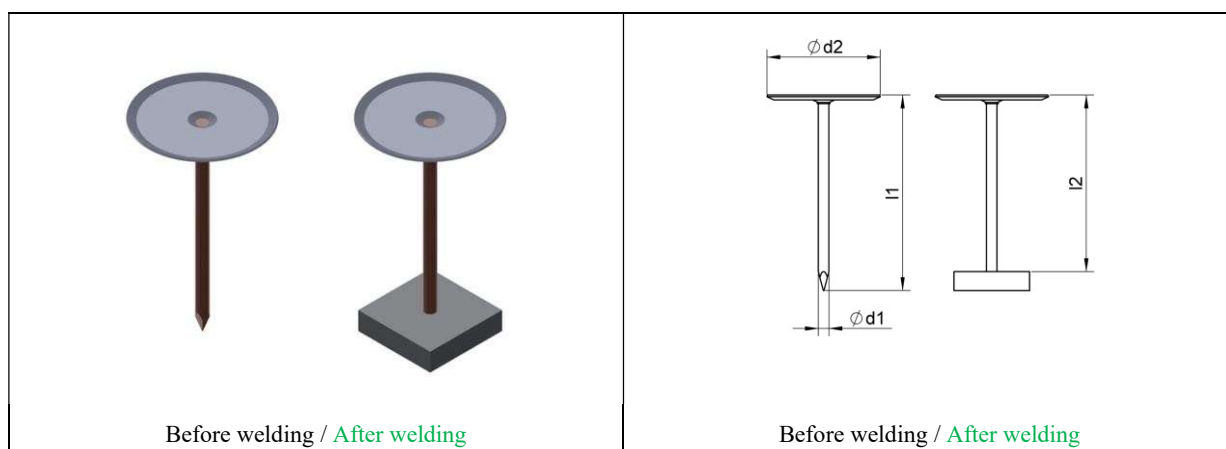

Dimensioni			for insulation (thickness in mm)	Material (item number)	
d1	l1	d2		Shaft: steel 4.8 copper-plated head: steel zinc-plated	Shaft: 1.4301 head: steel zinc-plated
2,7	14,5	30	15	On request	On request
2,7	19	30	20	On request	On request
2,7	22,2	30	20 (duro)	ATS4102,7022,2	On request
2,7	25,4	30	25	ATS4102,7025,4	On request
2,7	28,5	30	30	ATS4102,7028,5	On request
2,7	30,5	30	30	ATS4102,7030,5	On request
2,7	31,7	30	30 (duro)	On request	On request
2,7	35	30	35	ATS4102,7035	On request
2,7	38	30	40	On request	On request
2,7	41	30	40 (duro)	On request	On request
2,7	47,6	30	50	ATS4102,7047,6	On request
2,7	50	30	50 (duro)	ATS4102,7050	ATS42027050
2,7	54	30	60 (morbido)	On request	On request
2,7	58	30	60 (medio)	On request	On request
2,7	60,5	30	60 (medio)	On request	On request
2,7	62	30	60 (duro)	On request	On request
2,7	64	30	70 (morbido)	On request	On request
2,7	68	30	70 (medio)	On request	On request
2,7	72	30	70 (duro)	On request	On request
2,7	76	30	80	On request	On request
2,7	78	30	80	On request	On request
2,7	89	30	100	On request	On request
2,7	98,5	30	100	On request	On request
2,7	101,6	30	100 (medio)	On request	On request
2,7	105	30	100 (duro)	On request	On request
2,7	114,3	30	120	On request	On request
2,7	139,7	30	140	On request	On request
2,7	152,4	30	150	On request	On request

Explanations of the materials used can be found in chapter 1.1.

Sizes and materials not listed are available upon request.

1.16 Insulated pin nail with clip

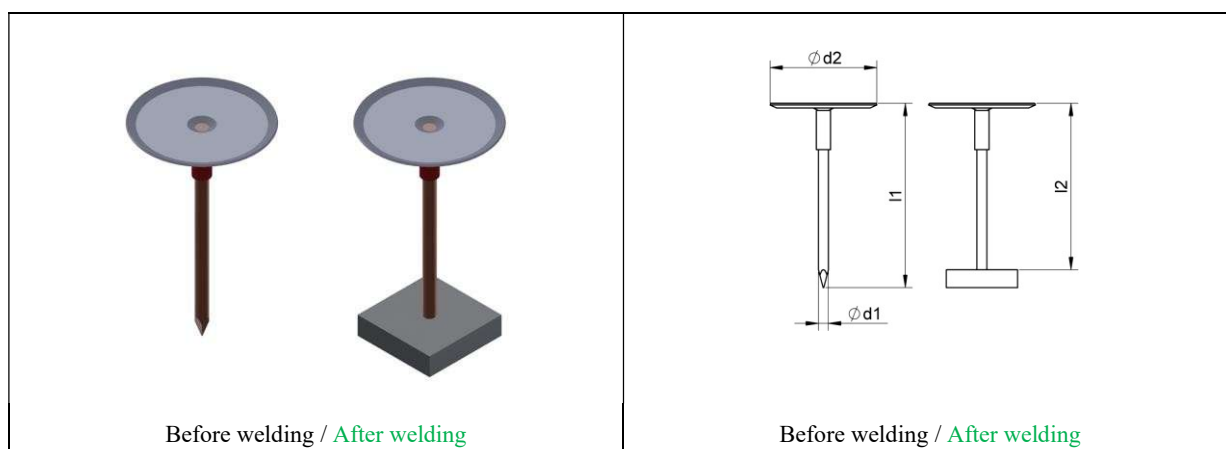

The shaft of the cupped head pin is insulated. Insulated cupped head pins are used for fixing insulating mats with aluminum lamination resp. wire gauze. In connection with the downholder of the stud welding gun the insulation prevents that a short circuit with the aluminum lamination resp. the wire gauze occurs during welding.

Dimensions			for insulation (thickness in mm) d ₁	Material (item number)	
d ₁	l ₁	d ₂		Shaft: steel 4.8 copper-plated head: steel zinc-plated	Shaft: 1.4301 head: steel zinc-plated
2,7	14,5	30	15	On request	On request
2,7	19	30	20	ATS4102,7019S	ATS42027019IS
2,7	22,2	30	20 (duro)	ATS4102,7022,2S	On request
2,7	25,4	30	25	ATS4102,7025,4S	On request
2,7	28,5	30	30	On request	On request
2,7	30,5	30	30	On request	On request
2,7	31,7	30	30 (duro)	On request	On request
2,7	35	30	35	On request	On request
2,7	38	30	40	On request	On request
2,7	41	30	40 (duro)	On request	On request
2,7	47,6	30	50	On request	On request
2,7	50	30	50 (duro)	On request	On request
2,7	54	30	60 (morbido)	On request	On request
2,7	58	30	60 (medio)	On request	On request
2,7	60,5	30	60 (medio)	On request	On request
2,7	62	30	60 (duro)	On request	On request
2,7	64	30	70 (morbido)	On request	On request
2,7	68	30	70 (medio)	On request	On request
2,7	72	30	70 (duro)	On request	On request
2,7	76	30	80	On request	On request
2,7	78	30	80	On request	On request
2,7	89	30	100	On request	On request
2,7	98,5	30	100	On request	On request
2,7	101,6	30	100 (medio)	On request	On request
2,7	105	30	100 (duro)	On request	On request
2,7	114,3	30	120	On request	On request
2,7	139,7	30	140	On request	On request
2,7	152,4	30	150	On request	On request

Explanations of the materials used can be found in chapter 1.1.

Sizes and materials not listed are available upon request.

1.17 Silicone cover cap

Silicone cover caps protect the mechanically important areas of the welding elements during painting and powder coating, as well as during the combustion process (permanent temperature $\leq 210^{\circ}\text{C}$, short temperature $\leq 300^{\circ}\text{C}$).

1.17.1 Silicone cover caps for threaded studs and non-threaded studs

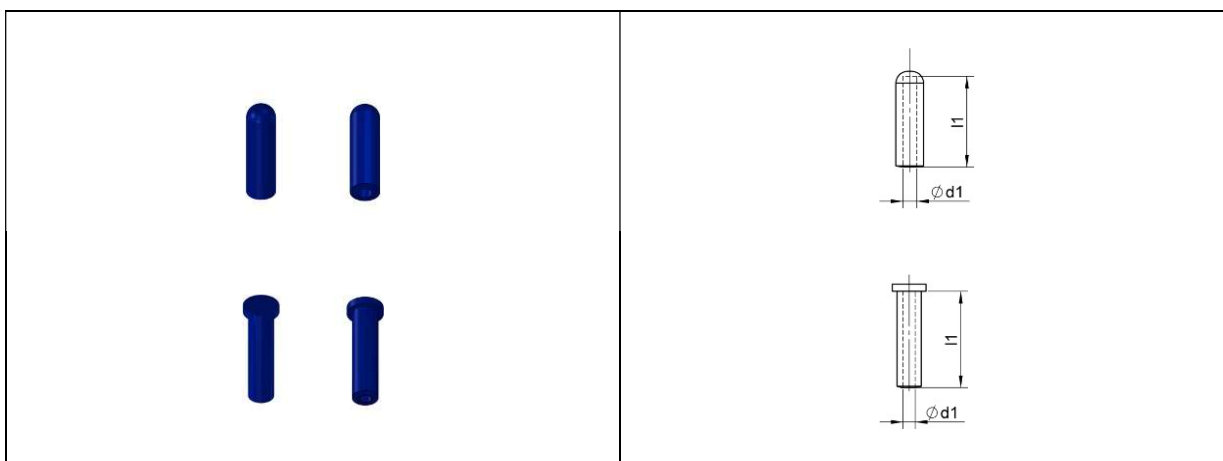

Sizes available on request.

1.17.2 Silicone cover caps for internally threaded studs

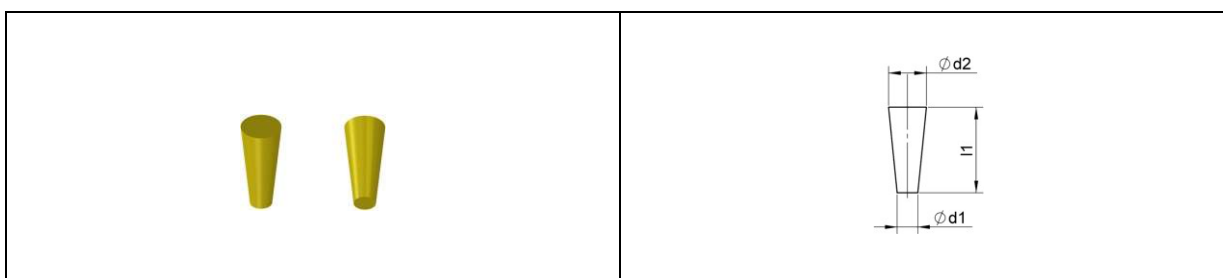

Sizes available on request.

1.17.3 Silicone Cover Caps for Earth Plug (Faston)



1.17.4 Silicone Cover Caps for Double Earth Plug (Faston)

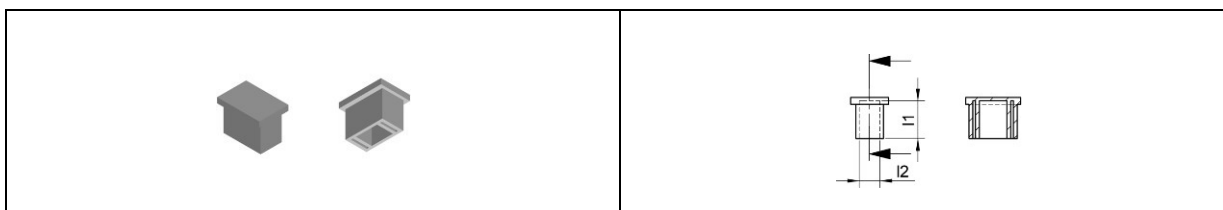

Annex: Accessories and Wear Parts for Stud Welding Guns

2. Accessories and wear parts of stud welding guns

2.1 Threaded stud (PT type), internally threaded stud (IT type), non-threaded stud (UT type), fir tree stud, self-tapping groove stud, threaded stud without flange, threaded stud with reduced flange diameter.

For stud welding guns PKM-1B, PHM-1A:

Stud dimensions		Gun accessories	
d ₁	l ₂	Chuck (item number)	Intermediate ring (item number)
M3 / 3	l ₂ ≤ 40 40 < l ₂ ≤ 55 55 < l ₂ ≤ 70	ATSPPPM3	- ATS80401128 ATS80401128 (2 pcs)
M4 / 4	l ₂ ≤ 40 40 < l ₂ ≤ 55 55 < l ₂ ≤ 70	ATSPPPM4	- ATS80401128 ATS80401128 (2 pcs)
M5 / 5	l ₂ ≤ 40 40 < l ₂ ≤ 55 55 < l ₂ ≤ 70	ATSPPPM5	- ATS80401128 ATS80401128 (2 pcs)
M6 / 6	l ₂ ≤ 40 40 < l ₂ ≤ 55 55 < l ₂ ≤ 70	ATSPPPM6	- ATS80401128 ATS80401128 (2 pcs)
7,1	l ₂ ≤ 40 40 < l ₂ ≤ 55 55 < l ₂ ≤ 70	ATSPPPM71	- ATS80401128 ATS80401128 (2 pcs)
M8 / 8	l ₂ ≤ 40 40 < l ₂ ≤ 55 55 < l ₂ ≤ 70	ATSPPPM8	- ATS80401128 ATS80401128 (2 pcs)
M10	l ₂ ≤ 25 25 < l ₂ ≤ 40 40 < l ₂ ≤ 55 55 < l ₂ ≤ 70	ATSPPPM10	ATS80401128 ATS80401128 (2 pcs) ATS80401128 (3 pcs) ATS80401128 (4 pcs)

2.2 Earth plug, double earth plug (Faston)

For stud welding guns PKM-1B, PHM-1A:

Type	Gun accessories
	Chuck (item number)
Earth plug	ATS8250050
Double earth plug	ATS8250050

For pin nails up to 200 mm in length, we offer the PKM-1B ISO-200 nail welding gun (part number ATS90102122)

2.3 Pin nail

For stud welding guns PKM-1B, PHM-1A:

Stud dimensions		Gun accessories
d ₁	l ₂	Chuck (item number)
2	l ₂ ≤ 145	ATS8250020
3	l ₂ ≤ 145	ATS8250030

2.4 Pin Nail With Clip, Insulated Pin Nail With Clip

For stud welding gun PIM-1B:

Stud dimensions			Gun accessories
d ₁	d ₂	l ₁	Chuck (item number)
2,7	30	l ₁ ≥ 9,5	ATS82500311

For stud welding gun PIM-1K:

Stud dimensions			Gun accessories
d ₁	d ₂	l ₁	Chuck (item number)
2,7	30	l ₁ ≥ 9,5	On request

3. Welding studs for drawn arc welding with ceramic ferrule

3.1 Technical Information

Flux (Aluminum Ball) and Weld Pool Support

According to DIN EN ISO 13918 (Welding - Ceramic pins and ferrules for arc welding) the welding pins for arc welding are equipped with an aluminum ball pressed onto the soldering tip. This serves as a flux to improve the ignition and stabilization of the electric arc and to deoxidize the weld pool.

(Exceptions: Insulating pins (type ISMS, ISA, ISB), bimetallic insulating pins (type VBS-MS, VBS) as well as balls do not have a pressed aluminum ball. Rectangular studs (types A, B and C) do not normally have a pressed aluminium ball, but can be produced with an aluminium ball on request).

Ceramic ferrules are usually used as a support for the weld pool. As a result, suitable ceramic ferrules are included in each prisoner expedition. A ceramic ferrule can only be used once; It is removed from the stud after welding, striking the ferrule itself.

As an alternative to ceramic ferrules, shielding gas can be used to support the weld pool. In this case, according to DIN EN ISO 13918, welding pins without pressed aluminum ball on the soldering tip are used.

Materials

Weld studs are manufactured from the following materials with excellent weldability:

Threaded studs, internally threaded studs, non-threaded studs and similar welding elements:

Material group/strength class	Norm
Steel 4.8	ISO 898-1
A2-50, A2-70A5-50, A5-70	ISO 3506-1

Shear connectors:

Material group/strength class	Norm
Killed steel acc. to material group 1 within limits acc. to DIN EN ISO 13918:2018: C ≤ 0,2%, CEV ≤ 0,38, Al ≤ 0,02% (e.g. S235J2+C470 acc. to EN 10025:2019)	ISO/TR 15608
Stainless steel 1.4301	EN 10088:2014

The material specifications are in accordance with DIN EN ISO 13918 and DIN EN ISO 14555. For welding studs of other materials, please send us your inquiry or contact us.

On request, the material properties can be checked with an inspection document (test report, inspection certificate) in accordance with DIN EN 10204.

We are happy to inform you about the weldability of the different base materials and the welding parameters.

Dimensions

The dimensions of the weld studs are shown in the measurement tables (all dimensions are in mm). All standardised weld studs comply with DIN EN ISO 13918. Non-standardised weld studs are supplied in accordance with DIN EN ISO 13918. Special welding elements, not described, are supplied on request.

Dimensions not listed in the measurement tables are provided upon request.

The nominal length (l₂) always corresponds to the length after welding. Depending on the diameter, the length before welding (l₁) is greater than a certain welding tolerance ranging from 1 to 5 mm.

Surface protection

Usually weld studs are supplied in glossy condition. On request, the following surface treatments are possible (coating thicknesses according to DIN EN ISO 4042):

1. Galvanically galvanized
2. Hot-dip galvanized
3. Zinc Flakes Coated fIZnnc-600h
4. Galvanized based on copper and galvanically nickel-plated
5. Galvanized with copper

Surface treatments 1, 2 and 3 have a negative impact on the quality of the weld and are therefore mechanically removed from the soldering tip. Like this:

- The tolerance for the diameter at the soldering tip (D₂ vs. D₁) is changed to -0.6/+0.1
- The tolerance for the Y dimension changes to -1/+0.5 compared to the measurement tables of this catalogue.

Threads

The stud threads are cold-rolled according to DIN 13-1 (tolerance limit 6g). For studs treated on the surface, the tolerance limit of 6h can be reached.

The thread of hot-dip galvanized studs is not true to the gauge. For hot-dip galvanized studs, you must use nuts with interference tolerance.

On request, we supply studs with special threads.

Weld fillet

During arc welding, a weld seam is formed between the welding element and the base material. The size of the weld seam is defined by the ceramic ferrule used and the welding parameters. The dimensions shown in the measurement tables are approximate values. The diameter of the weld seam is always greater than the nominal diameter of the weld element.

Stud Welding Gun Accessories

The accessories for the welding guns (chuck, ferrule handle, foot, etc.) must be adapted to the welding element.

3.2 Shear connector (type SD1 and SD3 according to DIN EN ISO 13918)

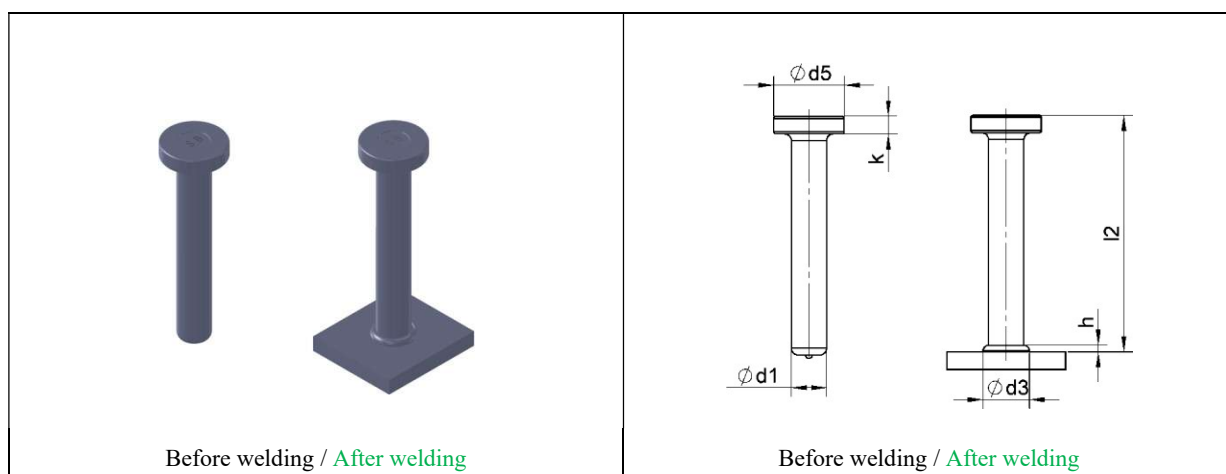

CE-conform. Our shear connectors (head marking: SB (for S235J2+C470) resp. A (for 1.4301)) fulfil all essential requirements of regulation (EU) Nr. 305/2011/EU (Construction Products Regulation).



European Technical Assessment ETA-11/0120 of the European Organisation for Technical Approvals (EOTA) issued by the German Institute of Civil Engineering (DIBt).

Dimensions						Material (item number)		Ceramic ferrule
d ₁ -0,4/0,4	l ₂	d ₅	k	d ₃ *	h*	S235J2+C470	1.4301	
10	50	19	7,1	13	2,5	ATS7510050	ATS75210050	UFN 10
10	75	19	7,1	13	2,5	ATS7510075	ATS75210075	UFN 10
10	100	19	7,1	13	2,5	ATS7510100	ATS75210100	UFN 10
10	125	19	7,1	13	2,5	ATS7510125	ATS75210125	UFN 10
10	150	19	7,1	13	2,5	ATS7510150	ATS75210150	UFN 10
10	175	19	7,1	13	2,5	ATS7510175	ATS75210175	UFN 10
10	200	19	7,1	13	2,5	ATS7510200	ATS75210200	UFN 10
10	225	19	7,1	13	2,5	ATS7510225	ATS75210225	UFN 10
10	250	19	7,1	13	2,5	ATS7510250	ATS75210250	UFN 10
13	50	25	8	17	3	ATS7513050	ATS75213050	UF 13
13	75	25	8	17	3	ATS7513075	ATS75213075	UF 13
13	100	25	8	17	3	ATS7513100	ATS75213100	UF 13
13	125	25	8	17	3	ATS7513125	ATS75213125	UF 13
13	150	25	8	17	3	ATS7513150	ATS75213150	UF 13
13	175	25	8	17	3	ATS7513175	ATS75213175	UF 13
13	200	25	8	17	3	ATS7513200	ATS75213200	UF 13
13	225	25	8	17	3	ATS7513225	ATS75213225	UF 13
13	250	25	8	17	3	ATS7513250	ATS75213250	UF 13
16	50	32	8	21	4,5	ATS7516050	ATS75216050	UF 16
16	75	32	8	21	4,5	ATS7516075	ATS75216075	UF 16
16	100	32	8	21	4,5	ATS7516100	ATS75216100	UF 16
16	125	32	8	21	4,5	ATS7516125	ATS75216125	UF 16

Dimensions						Material (item number)		Ceramic ferrule
d ₁ -0,4/0,4	l ₂	d ₅	k	d ₃ *	h*	S235J2+C470	1.4301	
16	150	32	8	21	4,5	ATS7516150	ATS75216150	UF 16
16	175	32	8	21	4,5	ATS7516175	ATS75216175	UF 16
16	200	32	8	21	4,5	ATS7516200	ATS75216200	UF 16
16	225	32	8	21	4,5	ATS7516225	ATS75216225	UF 16
16	250	32	8	21	4,5	ATS7516250	ATS75216250	UF 16
16	275	32	8	21	4,5	ATS7516275	ATS75216275	UF 16
16	300	32	8	21	4,5	ATS7516300	ATS75216300	UF 16
19	50	32	10	23	6	ATS7519050	ATS75219050	UF 19
19	60	32	10	23	6	ATS7519060	ATS75219060	UF 19
19	75	32	10	23	6	ATS7519075	ATS75219075	UF 19
19	80	32	10	23	6	ATS7519080	ATS75219080	UF 19
19	90	32	10	23	6	ATS7519090	ATS75219090	UF 19
19	100	32	10	23	6	ATS7519100	ATS75219100	UF 19
19	125	32	10	23	6	ATS7519125	ATS75219125	UF 19
19	150	32	10	23	6	ATS7519150	ATS75219150	UF 19
19	175	32	10	23	6	ATS7519175	ATS75219175	UF 19
19	200	32	10	23	6	ATS7519200	ATS75219200	UF 19
19	225	32	10	23	6	ATS7519225	ATS75219225	UF 19
19	250	32	10	23	6	ATS7519250	ATS75219250	UF 19
19	275	32	10	23	6	ATS7519275	ATS75219275	UF 19
19	300	32	10	23	6	ATS7519300	ATS75219300	UF 19
22	75	35	10	29	6	ATS7522075	ATS75222075	UF 22
22	90	35	10	29	6	ATS7522090	ATS75222090	UF 22
22	100	35	10	29	6	ATS7522100	ATS75222100	UF 22
22	125	35	10	29	6	ATS7522125	ATS75222125	UF 22
22	150	35	10	29	6	ATS7522150	ATS75222150	UF 22
22	175	35	10	29	6	ATS7522175	ATS75222175	UF 22
22	200	35	10	29	6	ATS7522200	ATS75222200	UF 22
22	225	35	10	29	6	ATS7522225	ATS75222225	UF 22
22	250	35	10	29	6	ATS7522250	ATS75222250	UF 22
22	275	35	10	29	6	ATS7522275	ATS75222275	UF 22
22	300	35	10	29	6	ATS7522300	ATS75222300	UF 22
25	75	41	12	31	7	ATS7525075		UF 25
25	100	41	12	31	7	ATS7525100		UF 25
25	125	41	12	31	7	ATS7525125		UF 25
25	150	41	12	31	7	ATS7525150		UF 25
25	175	41	12	31	7	ATS7525175		UF 25
25	200	41	12	31	7	ATS7525200		UF 25
25	225	41	12	31	7	ATS7525225		UF 25
25	250	41	12	31	7	ATS7525250		UF 25
25	275	41	12	31	7	ATS7525275		UF 25
25	300	41	12	31	7	ATS7525300		UF 25

*D3 and H are approximate values. Explanations of the materials used can be found in chapter 3.1. Special ceramic ferrules for welding pegs are given in Chapter 3.32, padded rings in Chapter 3.31. **Sizes and materials not listed are available upon request.**

3.3 Threaded stud with reduced shaft (type RD according to DIN EN ISO 13918)

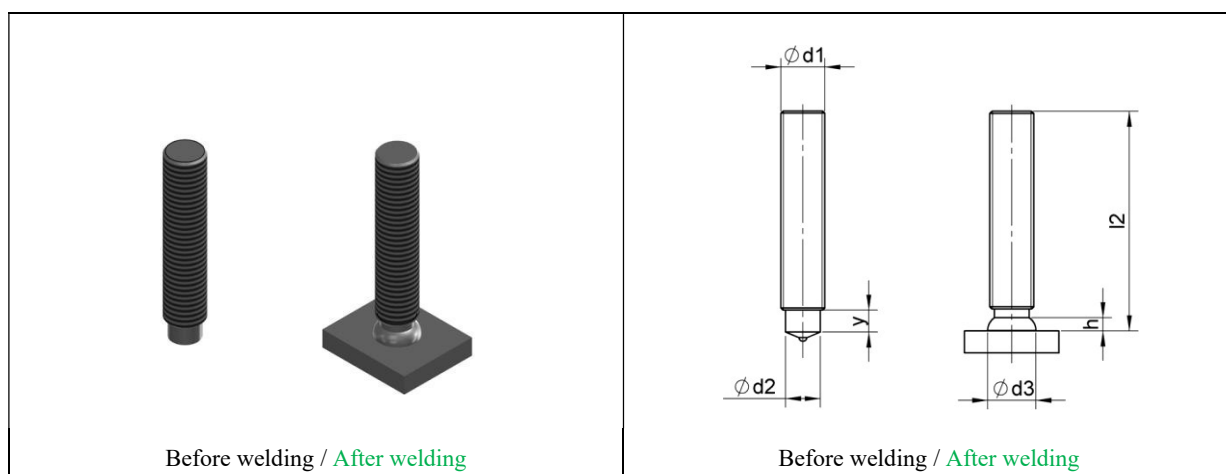

The threaded stud type RD is threaded almost to the top of the welding tip which is reduced to about the core diameter of the thread. Thus the fillet diameter will only be slightly (0,5-1 mm) bigger than the external diameter of the thread. It is worthy of note that the reduction of the welding tip diminishes the bearing force of the stud by approximately 15% in comparison to the type MD/PD/FD. Thus - if necessary - the next bigger diameter should be chosen.

Dimensions						Material (item number)			Ceramic ferrule
d ₁	l ₂	y ¹ -0/2P ²	d ₂ -0,1/0,1	d ₃ ³	h'	Steel 4.8	A2-50	A5-50	
M6	15-100	4	4,7	7	2,5	ATS01551 06XXX	ATS01552 06XXX	On request	RF 6
M8	15-100	4	6,2	9	2,5	ATS01551 08XXX	ATS01552 08XXX	On request	RF 8 (KSR-F 8 ³)
M10	15-100	5	7,9	11,5	3	ATS01551 10XXX	ATS01552 10XXX	On request	RF 10 (KSR-F 10 ³)
M12	20-100	6	9,5	13,5	4	ATS01551 12XXX	ATS01552 12XXX	On request	RF 12
M16	25-100	7,5	13,2	16,8	5	ATS01551 16XXX	ATS01552 16XXX	On request	RF 16
M16	25-100	11	13,2	16,1	5	On request	On request	On request	RF 16 (flat form)
M20	30-100	13	16,5	20,5	6	On request	On request	On request	RF 20 (flat form)
M24	50-100	15	20	28	7	ATS01551 24XXX	On request	On request	UF 20

¹Other sizes and sizes available upon request.

²P = thread pitch according to DIN 13-1

³for L₂ < 20 mm

*D₃ and H are approximate values.

The article number XXX must be replaced by the respective length of the welding element l₂ (e.g. 030 for 30 mm). Explanations of the materials used are given in chapter 3.1.

The available surface treatments are given in chapter 3.1.

Sizes and materials not listed are available upon request.

3.4 Threaded stud with practically complete thread (type MD according to DIN EN ISO 13918, before: type MPF)

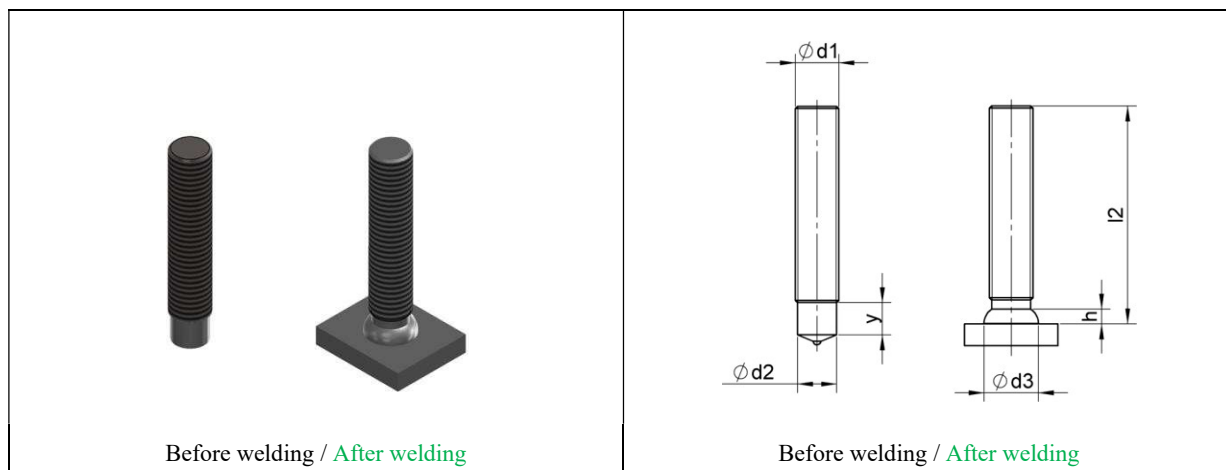

With the revision of April 2018 the stud type MD was included into DIN EN ISO 13918:2018 for the first time. The stud type MD acc. to DIN EN ISO 13918:2018 is mostly identical to the not standardised stud type MPF which we already produced for many years. There are only deviations regarding the dimension y (non-threaded part) for M6 (before: 3 mm), M10 (before: 7 mm) and M12 (before: 8 mm).

The threaded stud type MD is threaded to approximately the top of the welding tip. The diameter of the unthreaded stud section on the welding tip corresponds to the pitch diameter of the thread. Thus the diameter of the weld-fillet is approximately 3-4 mm larger than the external diameter of the thread.

Dimensions						Material (item number)			Ceramic ferrule
d_1	l_2	y -0/+0,5	d_2 -0,1/0,1	d_3^*	h^*	Steel 4.8	A2-50	A5-50	
M6	15-100	5,5	5,3	8,5	4	On request	On request	On request	UF 6
M8	15-100	6	7,1	10	3	On request	On request	On request	MF 8
M10	15-100	6,5	8,95	12,5	3,4	On request	On request	On request	MF 10
M12	20-100	7,5	10,8	14,5	4,2	On request	On request	On request	MF 12
M16	30-100	11	14,6	17,8	5,8	On request	On request	On request	MF 16
M20	35-100	13	18,3	22,5	6,6	On request	On request	On request	MF 20
M24	35-100	23,5	22	29	6	On request	On request	On request	UF 22

*D3 and H are approximate values.

In article number **XXX** it must be replaced by the respective length of the welding element l_2 (e.g. 030 for 30 mm). Explanations of the materials used can be found in Chapter 3.1.

The available surface treatments are given in chapter 3.1.

Sizes and materials not listed are available upon request.

3.5 Threaded stud with partial thread (type PD acc.to DIN EN ISO 13918)

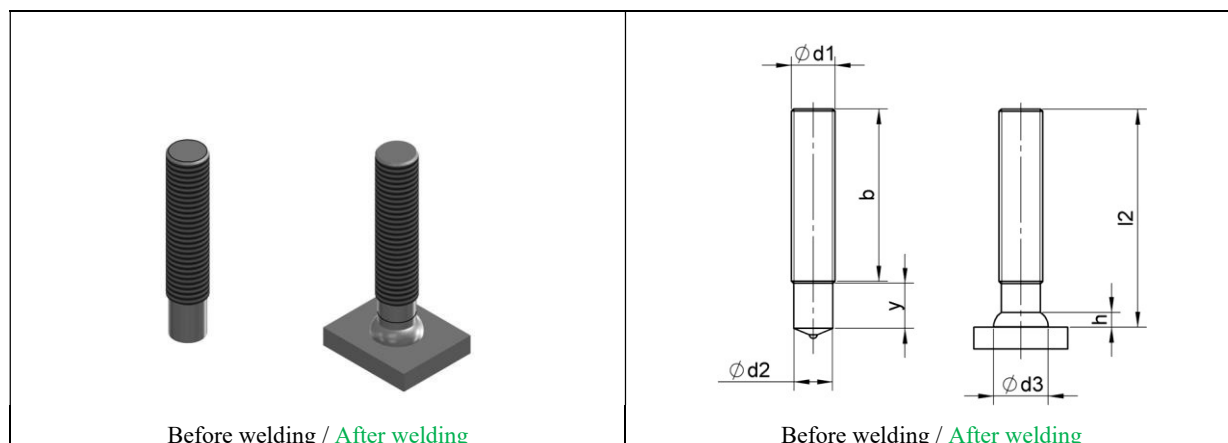

The threaded stud type PD has a partial thread. The diameter of the unthreaded stud section on the welding tip corresponds to the pitch diameter of the thread. Thus the diameter of the weld-fillet is approximately 3-4 mm larger than the external diameter of the thread.

Dimensions							Material (item number)			Ceramic ferrule
d ₁	l ₂	y -0,2P ¹	b	d ₂ -0,1/0,1	d ₃ [*]	h [*]	Steel 4.8	A2-50	A5-50	
M6	15 ≤ l ₂ < 35 35 ≤ l ₂ < 65 65 ≤ l ₂ < 160	9 - -	- 20 40	5,3	8,5	3,5	On request	On request	On request	PF 6
M8	20 ≤ l ₂ < 50 50 ≤ l ₂ < 160 l ₂ ≥ 160	9 - -	- 40 40	7,1	10	3,5	ATS0156108XXX	On request	On request	PF 8
M10	20 ≤ l ₂ < 50 50 ≤ l ₂ < 140 140 ≤ l ₂ ≤ 160	9,5 - -	- 40 80	8,95	12,5	4	ATS01561010XXX	ATS01562010XXX	On request	PF 10
M12	25 ≤ l ₂ < 50 50 ≤ l ₂ < 140 140 ≤ l ₂ ≤ 160	11,5 - -	- 40 80	10,8	15,5	4,5	ATS01561012XXX	ATS01562012XXX	On request	PF 12
M16	30 ≤ l ₂ < 55 55 ≤ l ₂ < 70 70 ≤ l ₂ < 100 100 ≤ l ₂ ≤ 160	13,5 - - -	- 40 50 80	14,6	19,5	6	ATS01561016XXX	On request	On request	PF 16
M20	35 ≤ l ₂ < 50 50 ≤ l ₂ < 55 55 ≤ l ₂ < 70 70 ≤ l ₂ < 100 100 ≤ l ₂ ≤ 160	15,5 - - - -	- 35 40 50 70	18,3	22,5	7	Su richiesta	On request	On request	MF 20
M24	50 ≤ l ₂ < 55 55 ≤ l ₂ < 70 70 ≤ l ₂ < 100 100 ≤ l ₂ < 150 150 ≤ l ₂ ≤ 160	20 - - - -	- 30 50 70 100	22	30	10	Su richiesta	On request	On request	UF 22

1P = thread pitch according to DIN 13-1

*D₃ and H are approximate values.

In article number **XXX** it must be replaced by the respective length of the welding element l₂ (e.g. 030 for 30 mm). Explanations of the materials used can be found in Chapter 3.1.

The available surface treatments are given in chapter 3.1.

Sizes and materials not listed available upon request.

3.6 Threaded stud with full thread (type FD according to DIN EN ISO 13918)

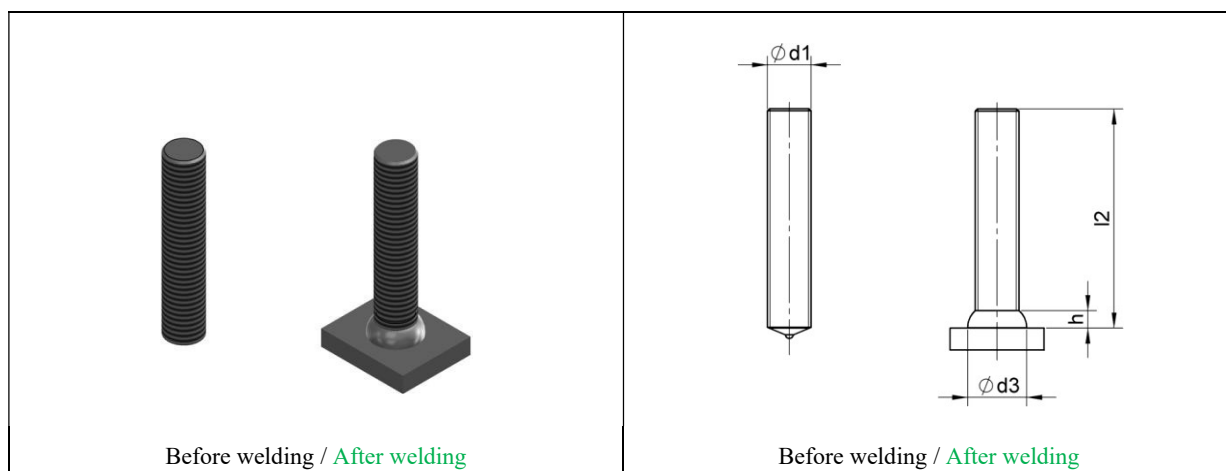

The threaded stud type FD is threaded to the top of the welding tip. Thus after welding the stud is threaded up to the weld-fillet. The diameter of the weld-fillet is approximately 3-4 mm larger than the external diameter of the thread.

Dimensions				Material (item number)			Ceramic ferrule
d_1	l_2	d_3'	h'	Steel 4.8	A2-50	A5-50	
M6	15-100	8,5	4	On request	On request	On request	UF 6
M8	15-100	11	4	On request	On request	On request	UF 8
M10	15-100	13	4	On request	On request	On request	UF 10
M12	20-100	16	5	On request	On request	On request	UF 12
M16	25-100	21	7	On request	On request	On request	UF 16
M20	30-100	26	7	On request	On request	On request	UF 20

*D3 and H are approximate values.

In article number **XXX** it must be replaced by the respective length of the welding element l_2 (e.g. 030 for 30 mm). Explanations of the materials used can be found in Chapter 3.1.

The available surface treatments are given in chapter 3.1.

Sizes and materials not listed available upon request.

3.7 Internally threaded stud (type ID according to DIN EN ISO 13918)

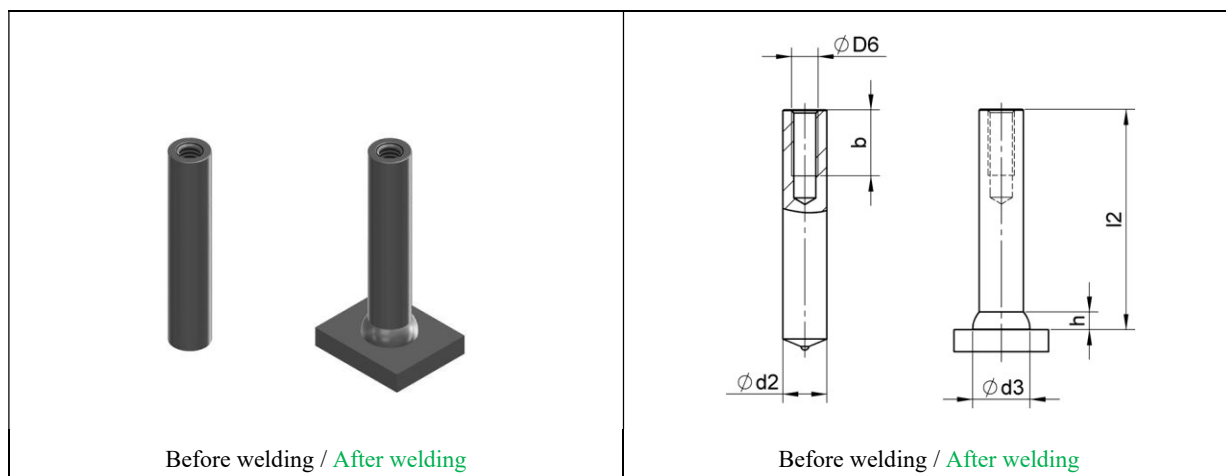

Dimensions						Material (item number)			Ceramic ferrule
D ₆	b +2P ¹	d ₂ -0,1/0,1	l ₂	d ₃ ²	h ³	Steel 4.8	A2-50	A5-50	
M5	7	10	15-100	13	4	On request	On request	On request	UF 10 (KSN-F 10 ²)
M6	9 (7 ²)	10	15-100	13	4	On request	On request	On request	UF 10 (KSN-F 10 ²)
M8	12 (8 ²)	12	15-100	16	5	On request	On request	On request	UF 12 (KSN-F 12 ²)
M8	12 (8 ²)	14,6	15-100	18,5	6	On request	On request	On request	MF 16
M10	15 (8 ³)	14,6	15-100	18,5	6	On request	On request	On request	MF 16
M10	15 (8 ³)	16	20-100	21	7	On request	On request	On request	UF 16
M12	18	18,3	25-100	23	7	On request	On request	On request	MF 20
M16	24	22	40-100	28	10	On request	On request	On request	UF 22

¹P = thread pitch according to DIN 13-1

²for L₂ < 20 mm, ³for L₂ < 25 mm

*D₃ and H are approximate values.

In article number XXX it must be replaced by the respective length of the welding element l₂ (e.g. 030 for 30 mm).

The available surface treatments are given in chapter 3.1.

Sizes and materials not listed available upon request.

3.8 Non-threaded stud (type UD according to DIN EN ISO 13918)

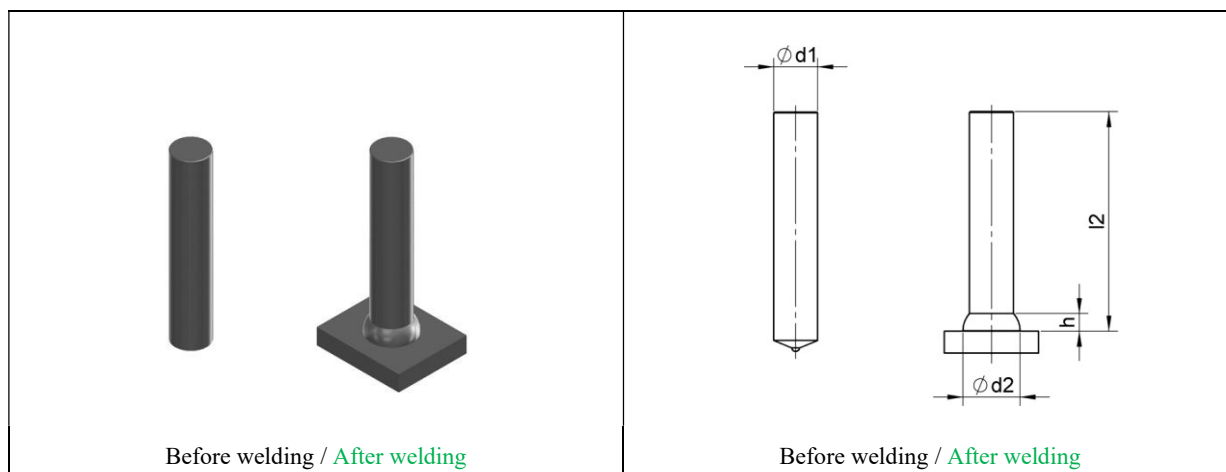

Dimensions				Material (item number)			Ceramic ferrule
d_1 -0,1/0,1	l_2	d_2^*	h^*	Steel 4.8	A2-50	A5-50	
6	15-100	8,5	4	On request	On request	On request	UF 6
8	15-100	11	4	ATS5608XXX	On request	On request	UF 8
10	15-100	13	4	On request	On request	On request	UF 10 (KSN-F 10')
12	15-100	16	5	On request	On request	On request	UF 12 (KSN-F 12')
14,6	20-100	18,5	6	On request	On request	On request	MF 16
16	30-100	21	7	On request	On request	On request	UF 16
20	40-100	26	9	On request	On request	On request	UF 20
22	40-100	28	10	On request	On request	On request	UF 22

¹ for $L_2 < 20$ mm

* d_2 and h are approximate values.

In article number **XXX** it must be replaced by the respective length of the welding element l_2 (e.g. 030 for 30 mm). Explanations of the materials used can be found in Chapter 3.1.

The available surface treatments are given in chapter 3.1.

Sizes and materials not listed available upon request.

3.9 Bimetal threaded stud with practically complete thread (type MD-DUO, before: type MPF-DUO)

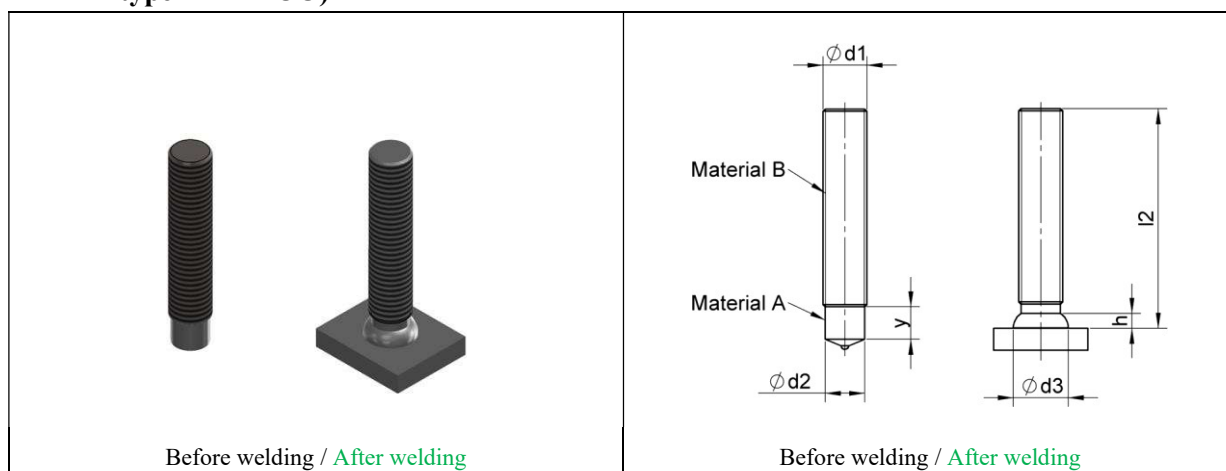

The threaded stud type MD-DUO consists of two different materials. It is threaded to approximately the top of the welding tip. The diameter of the unthreaded stud section on the welding tip corresponds to the pitch diameter of the thread. Thus the diameter of the weld-fillet is approximately 3-4 mm larger than the external diameter of the thread.

Dimensions						Material (item number)		Ceramic ferrule
d ₁	l ₂	y -0/+0,5	d ₂ -0,1/0,1	d ₃ *	h*	A: steel 4.8, B: A5-50	A: steel 4.8, B: A2-50	
M8	15-100	6	7,1	10	3	On request	On request	MF 8
M10	20-100	6,5	8,95	12,5	3,4	On request	On request	MF 10
M12	20-100	7,5	10,5	14,5	4,2	On request	On request	MF 12
M16	30-100	11	14,6	17,8	5,8	On request	On request	MF 16

*D3 and H are approximate values.

In article number **XXX** it must be replaced by the respective length of the welding element l₂ (e.g. 030 for 30 mm). Explanations of the materials used can be found in Chapter 3.1.

Sizes and materials not listed available upon request.

3.10 Bimetallic threaded stud with partial thread (type PD-DUO)

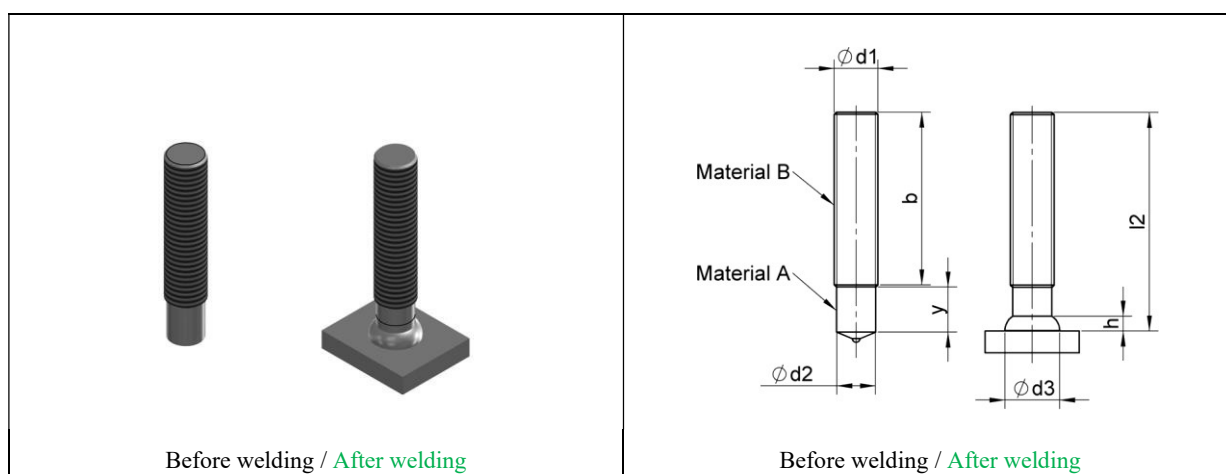

The PD-DUO type threaded stud is made of two different materials. It has a partial thread. The cross-section diameter of the non-threaded pin on the soldering tip corresponds to the diameter of the thread pitch. Therefore, the diameter of the weld thread is about 3-4 mm larger than the outer diameter of the thread. **Sizes and materials available on request.**

3.11 Bimetallic threaded stud with reduced shaft (type RD-DUO)

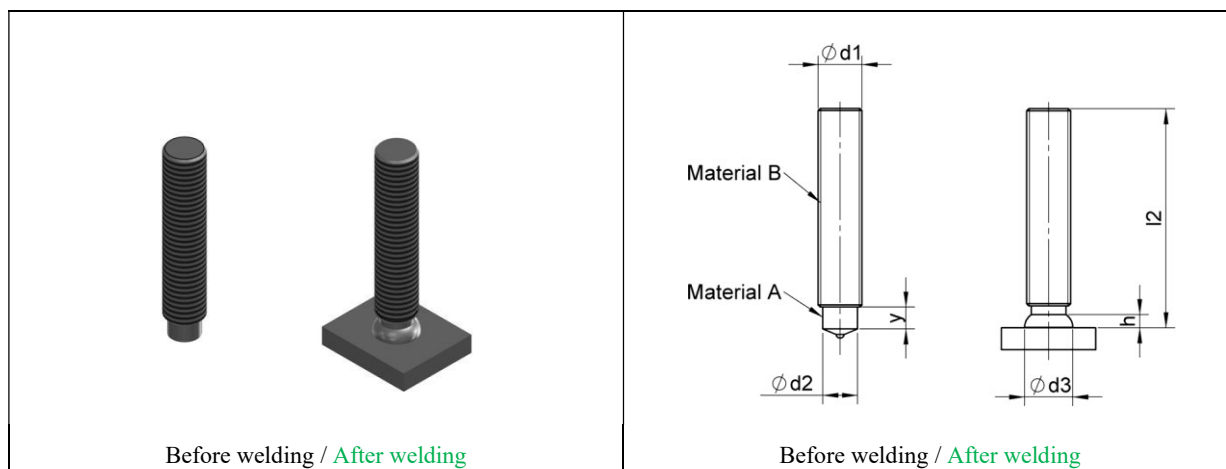

The threaded stud type RD-DUO consists of two different materials. It is threaded almost to the top of the welding tip which is reduced to about the core diameter of the thread. Thus the fillet diameter will only be slightly (0,5-1 mm) bigger than the external diameter of the thread. It is worthy of note that the reduction of the welding tip diminishes the bearing force of the stud by approximately 15% in comparison to the type MD/PD/FD. Thus - if necessary - the next bigger diameter should be chosen.

Dimensions						Material (item number)		Ceramic ferrule
d_1	l_2	y^1 <small>-0/2P²</small>	d_2 <small>-0,1/0,1</small>	d_3^*	h^*	A: steel 4.8, B: A5-50	A: steel 4.8, B: A2-50	
M8	15-100	4	6,2	9	2,5	On request	On request	RF 8 (KSR-F 8 ³)
M10	20-100	5	7,9	11,5	3	On request	On request	RF 10
M12	20-100	6	9,5	13,5	4	On request	On request	RF 12
M16	25-100	7,5	13,2	16,8	5	On request	On request	RF 16
M16	25-100	11	13,2	16,1	5	On request	On request	RF 16 (flat form)

¹Other y-dimensions available upon request. ²P = thread pitch according to DIN 13-1. 3 for $L_2 < 20$ mm
^{*}D3 and H are approximate values.

The article number **XXX** must be replaced by the respective length of the welding element l_2 (e.g. 030 for 30 mm). Explanations of the materials used can be found in Chapter 3.1.

Sizes and materials not listed are available upon request.

3.12 Bimetallic internally threaded stud (type ID-DUO)

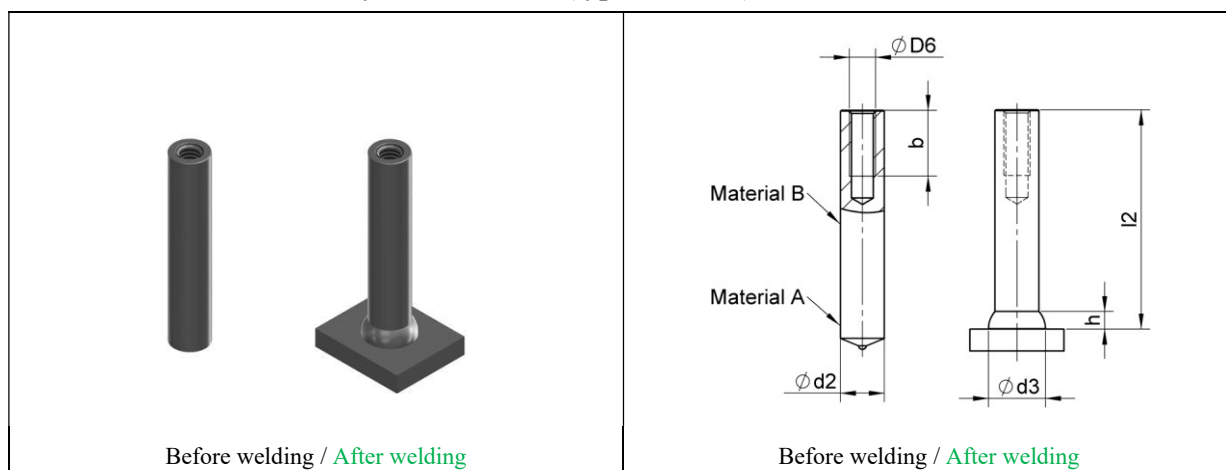

Sizes and materials available on request.

3.13 Insulation pins and clips

3.13.1 Insulation pin (type ISMS)

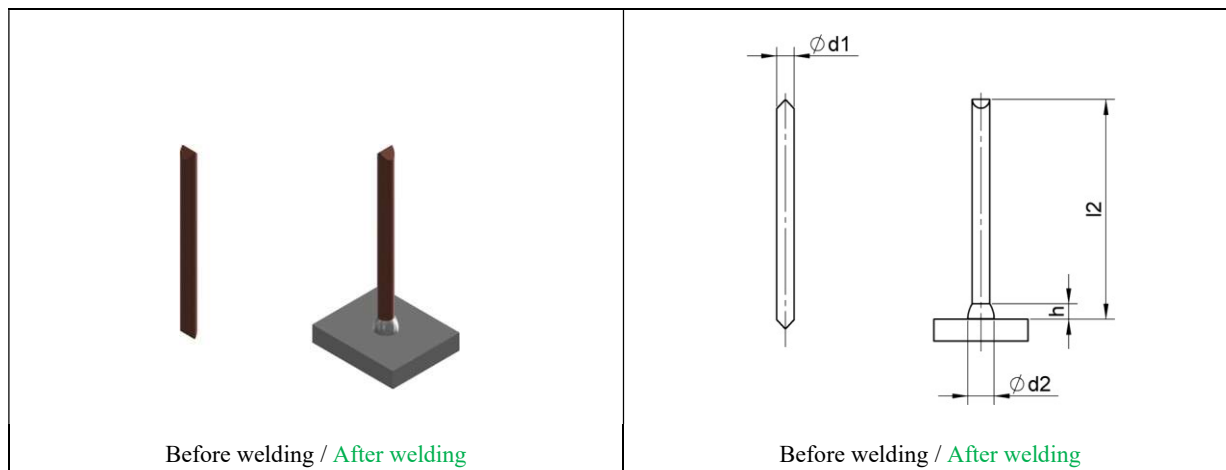

Insulation pin - two-sided with chisel tip

Dimensions				Material (item number)					[Ceramic ferrule ¹]
d ₁	l ₂	d ₂ [*]	h [*]	Steel 4.8 copper-plated	1.4301	1.4541	1.4571	1.5415 (16Mo3)	
3	20-450	6	3,5	On request	On request	On request	On request	On request	[UF 4' / K 5']
4	60-450	6	3,5	On request	-	-	-	-	[UF 4' / K 5']
5	60-120	8	3,5	On request	-	-	-	-	[UF 5' / K 5']

*d₂ and h are approximate values.

1Pin nails are usually welded without ceramic splints. Ceramic ferrules are only used for special applications. If you are using ceramic ferrules, you can choose between UF type and K type.

In article number **XXX** it must be replaced by the length l₂ of the respective welding element (e.g. 030 by 30 mm). Explanations of the materials used can be found in Chapter 3.1.

Sizes and materials not listed are available upon request.

3.13.2 Insulation pic (type ISA)

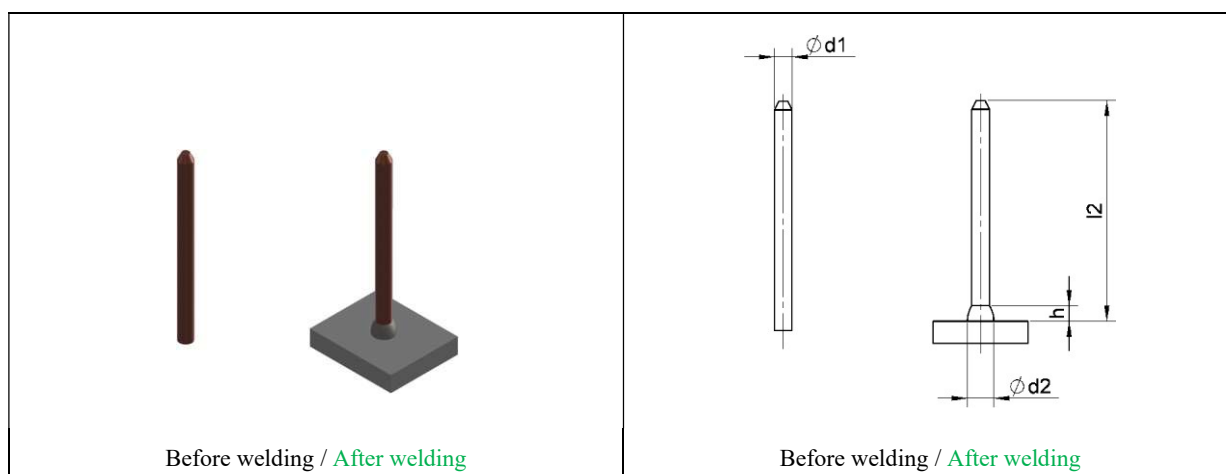

Insulation pin - one-sided with grinded tip

Dimensions				Material (item number)					[Ferula ceramica ']
d ₁	l ₂	d ₂ '	h'	Steel 4.8 copper-plated	1.4301	1.4541	1.4571	1.5415 (16Mo3)	
3	35-450	6	3,5	On request	On request	On request	On request	On request	[UF 4' / K 5']
4	60-450	6	3,5	On request	On request	On request	On request	On request	[UF 4' / K 5']
5	60-450	8	3,5	On request	On request	On request	On request	On request	[UF 5' / K 5']
6	60-450	8,5	4	On request	On request	On request	On request	On request	[UF 6' / K 6']

*d₂ and h are approximate values.

1Pin nails are usually welded without ceramic splints. Ceramic ferrules are only used for special applications. If you are using ceramic ferrules, you can choose between UF type and K type.

The article number **XXX** must be replaced by the length l₂ of the welding element (e.g. 030 for 30 mm). Explanations of the materials used can be found in Chapter 3.1.

Sizes and materials not listed are available upon request.

3.13.3 Insulation pin (type ISB)

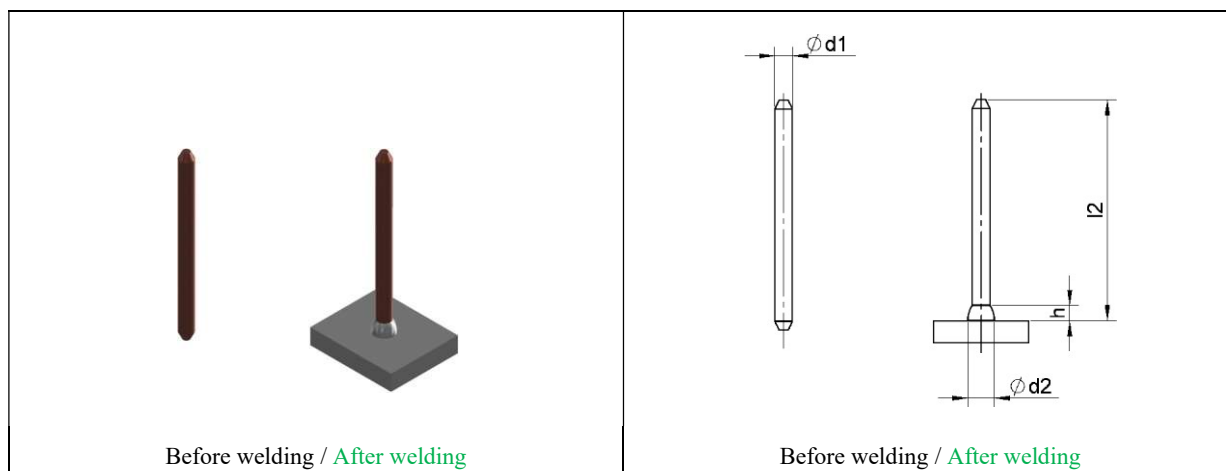

Insulation pin - two-sided with grinded tip

Dimensions				Material (item number)					[Ceramic ferrule*]
d ₁	l ₂	d ₂ *	h*	Steel 4.8 copper-plated	1.4301	1.4541	1.4571	1.5415 (16Mo3)	
3	50-450	6	3,5	On request	On request	On request	On request	On request	[UF 4' / K 5']
4	50-450	6	3,5	On request	On request	On request	On request	On request	[UF 4' / K 5']
5	50-450	8	3,5	On request	On request	On request	On request	On request	[UF 5' / K 5']
6	50-450	8,5	4	On request	On request	On request	On request	On request	[UF 6' / K 6']

*d₂ and h are approximate values.

1Pin nails are usually welded without ceramic splints. Ceramic ferrules are only used for special applications. If you are using ceramic ferrules, you can choose between type UF and type K.

In article number XXX it must be replaced by the respective length of the welding element l₂ (e.g. 030 for 30 mm).

Explanations of the materials used can be found in Chapter 3.1.

Sizes and materials not listed are available upon request.

3.13.4 Bimetallic insulation pin (type VBS-MS)

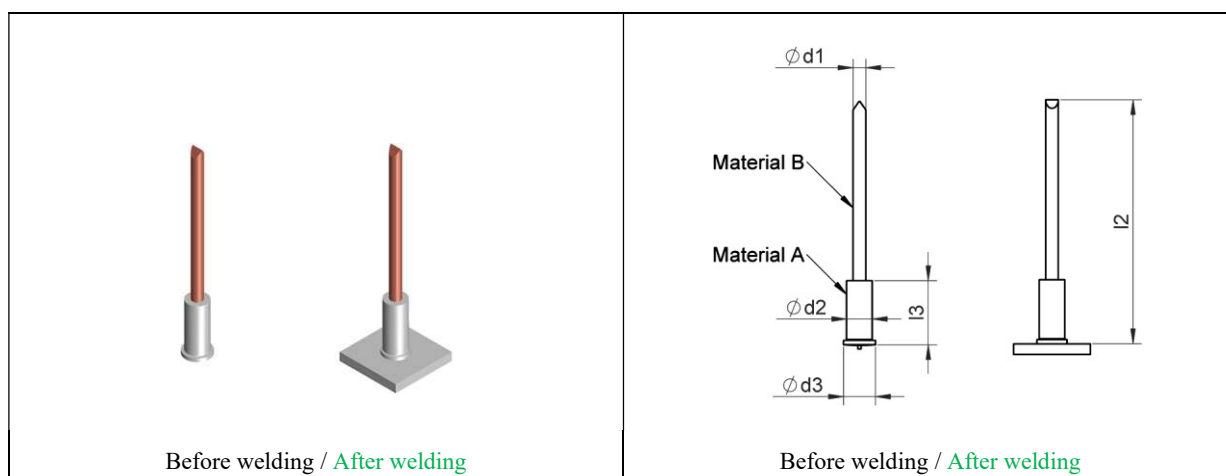

The bimetallic insulation pin VBS-MS consists of an aluminium tapped blind hole stud with a pressed-in insulation pin one-sided with chisel tip.

Application area: insulation on aluminium base material

Dimensions					Material (item number)		
d ₁	l ₂	d ₂	l ₃	d ₃	A: AlMg3, B: Steel 4.8 copper-plated	A: AlMg3, B: 1.4301	A: AlMg3, B: 1.4571
3	30-200	6	15	7,5	On request	On request	On request

In article number **XXX** it must be replaced by the respective length of the welding element l₂ (e.g. 030 for 30 mm). Explanations of the materials used can be found in chapter 3.1.

Sizes and materials not listed available upon request.

3.13.5 Bimetallic insulation pin (type VBS)

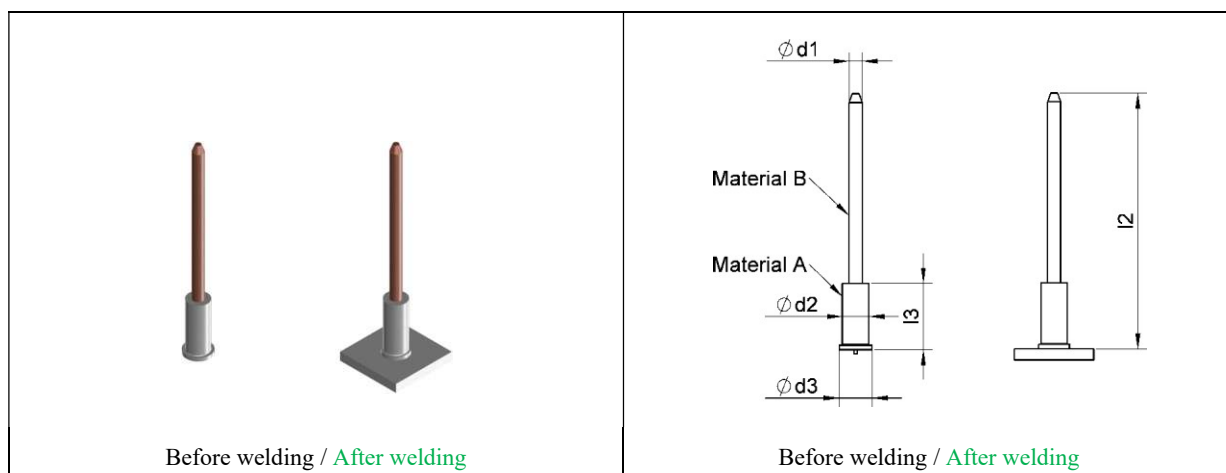

The VBS bimetal insulating stud consists of an aluminum threaded blind hole stud with a one-sided molded insulating stud with ground tip.

Application area: insulation on aluminium base material

Dimensions					Material (item number)		
d ₁	l ₂	d ₂	l ₃	d ₃	A: AlMg3, B: Steel 4.8 copper-plated	A: AlMg3, B: 1.4301	A: AlMg3, B: 1.4571
3	30-200	6	15	7,5	On request	On request	On request

In article number **XXX** it must be replaced by the respective length of the welding element l₂ (e.g. 030 for 30 mm). Explanations of the materials used can be found in Chapter 3.1.

Sizes and materials not listed are available upon request.

3.13.6 Insulation pin (type ISH)

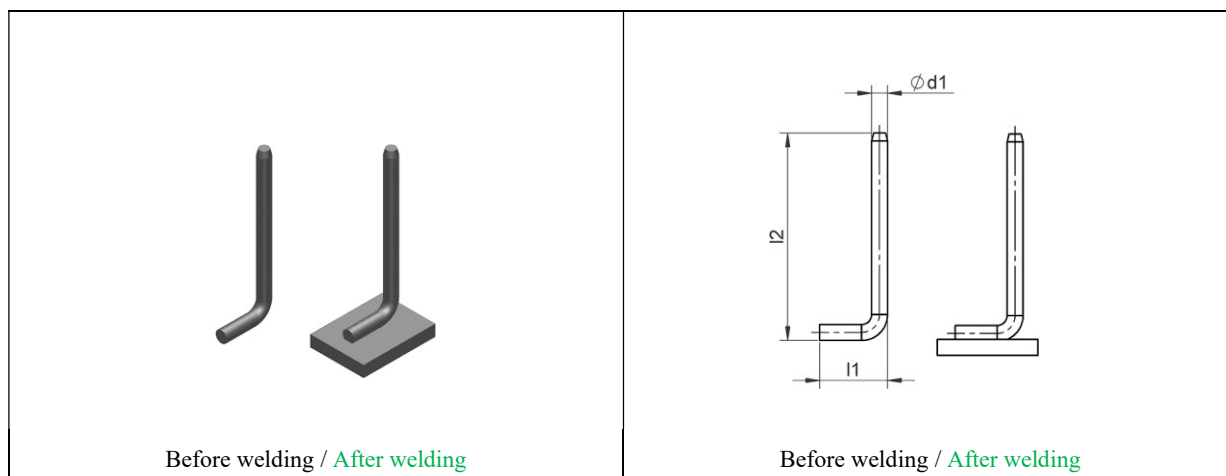

Insulation pin - angled (for manual welding)

Dimensions			Material (item number)				
d1	l2	l1	Steel 4.8 copper-plated	1.4301	1.4541	1.4571	1.5415 (16Mo3)
3	On request	On request	On request	On request	On request	On request	On request
4	On request	On request	On request	On request	On request	On request	On request
5	On request	On request	On request	On request	On request	On request	On request

In article number **XXX** it must be replaced by the respective welding element length l2 (e.g. 030 for 30 mm) and **XX** by the respective angular length l1.

Explanations of the materials used can be found in chapter 3.1.

Sizes and materials not listed available upon request.

3.13.7 Clip for insulation pin (type R)

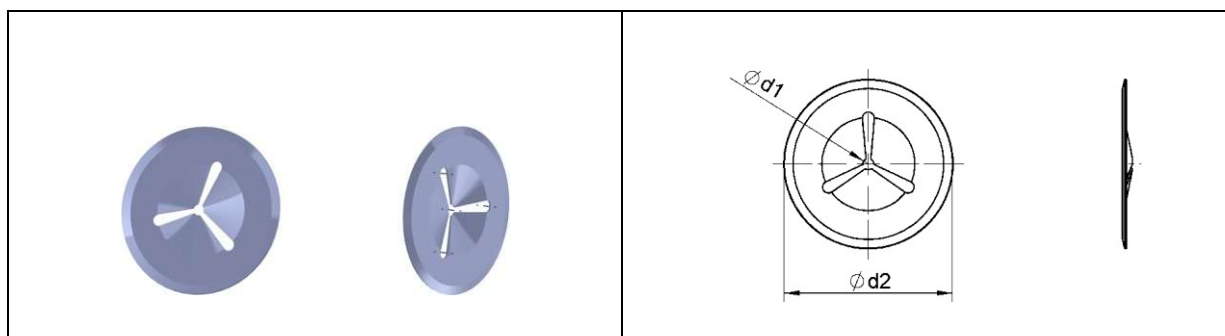

Dimensions		Material (item number)	
d ₁	d ₂	Steel zinc-plated	1.4310
2	38	ATS4912002	ATS4922002
3	38	ATS4913003	ATS4923003
4	38	ATS4914004	ATS4924004
5	38	ATS4915005	ATS4925005
6	38	ATS4916006	ATS4926006
8	38	ATS4918008	ATS4928008
9,5	38	ATS4919009,5	ATS4929009,5
12	38	ATS4912012	ATS4922012
3	60	ATS4913003ST2K70D60	ATS49230034310D60
4	60	ATS4914004ST2K70D60	ATS49240044310D60
5	60	ATS4915005ST2K70D60	ATS49250054310D60
6	60	ATS4916006ST2K70D60	ATS49260064310D60

Sizes and materials not listed available upon request.

3.13.8 Clip with plastic cap for insulation pin (type W)

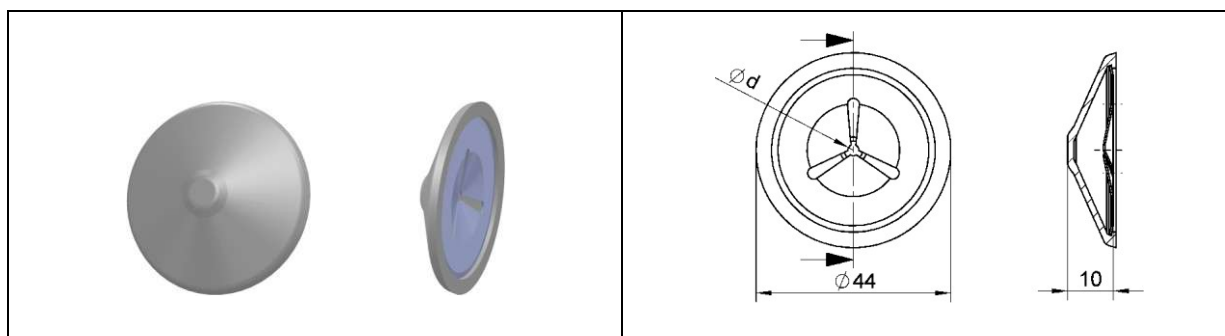

Dimensions	Material (item number)			
	Steel zinc-plated with plastic cap (white)	Steel zinc-plated with plastic cap (black)	1.4310 with plastic cap (white)	1.4310 with plastic cap (black)
d	On request	On request	On request	On request
2	On request	On request	On request	On request
3	ATS4953003	ATS4953003N	On request	ATS4963003N
4	On request	On request	On request	On request
5	On request	On request	On request	On request

Plastic cap: halogen-free, self-extinguishing

Sizes and materials not listed are available upon request.

3.14 Rectangular stud (type A)

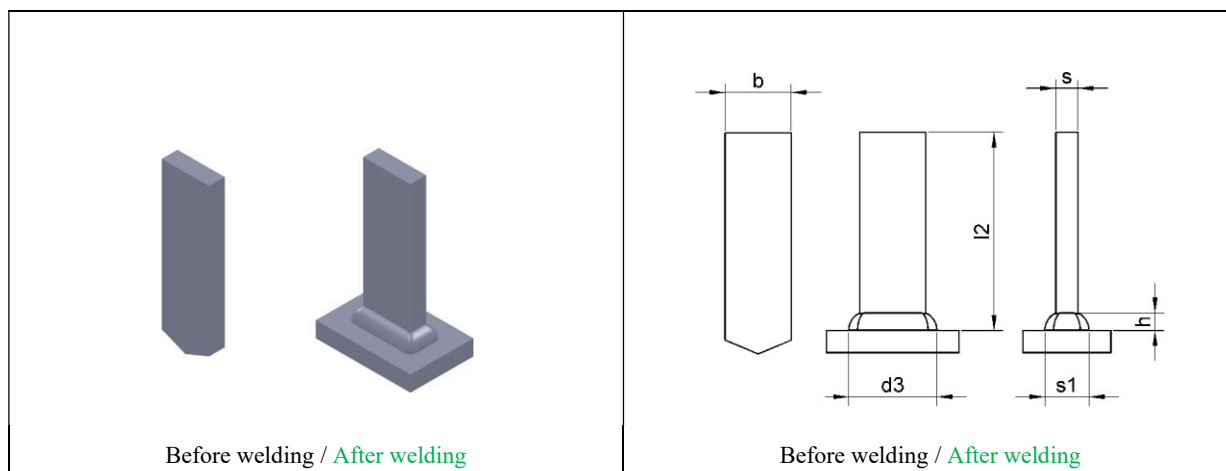

Dimensions						Material (item number)		Ceramic ferrule
b	s	l_2	d_3^*	h^*	s_1^*	Acciaio 4.8	A2-50	
15	3	20-100	18	4	6	On request	On request	KF 15x3
15	5	20-100	20	4	10	On request	On request	KF 15x5
25	3	25-100	28	4	6	On request	On request	KF 25x3
25	5	25-100	28	4	10	On request	On request	KF 25x5

*D3, H, and S1 are approximate values.

Rectangular studs (type A) do not normally have a pressed aluminium ball, but can be produced with an aluminium ball on request. In article number **XXX** it must be replaced by the respective length of the welding element l_2 (e.g. 030 for 30 mm). Explanations of the materials used can be found in Chapter 3.1.

The available surface treatments are given in chapter 3.1.

Sizes and materials not listed are available upon request.

3.15 Rectangular stud (type B)

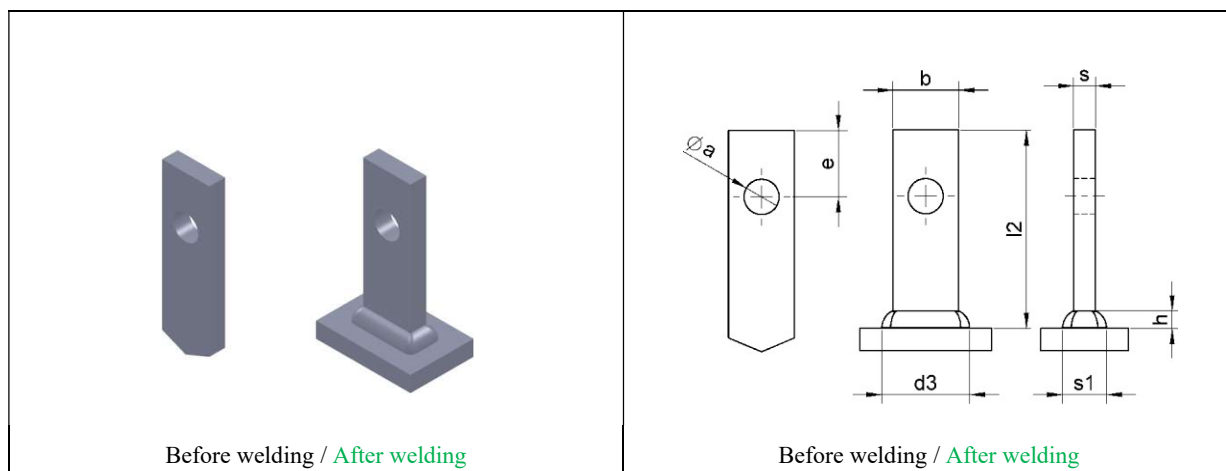

Dimensions								Material (item number)		Ceramic ferrule
b	s	l ₂	a	e	d ₃ *	h*	s ₁ *	Steel 4.8	A2-50	
15	3	20-100	6	15 (10 ¹)	18	4	6	On request	On request	KF 15x3
15	5	20-100	8	15 (10 ¹)	20	4	10	On request	On request	KF 15x5
25	3	25-100	8	15	28	4	6	On request	On request	KF 25x3
25	5	25-100	8	15	28	4	10	On request	On request	KF 25x5

¹ for L₂ < 25 mm

*D₃, H, and S₁ are approximate values.

Rectangular studs (type B) do not normally have a pressed aluminium ball, but can be produced with an aluminium ball on request.

In article number XXX it must be replaced by the respective length of the welding element l₂ (e.g. 030 for 30 mm). Explanations of the materials used can be found in Chapter 3.1.

The available surface treatments are given in chapter 3.1.

Sizes and materials not listed are available upon request.

3.16 Rectangular stud (type C)

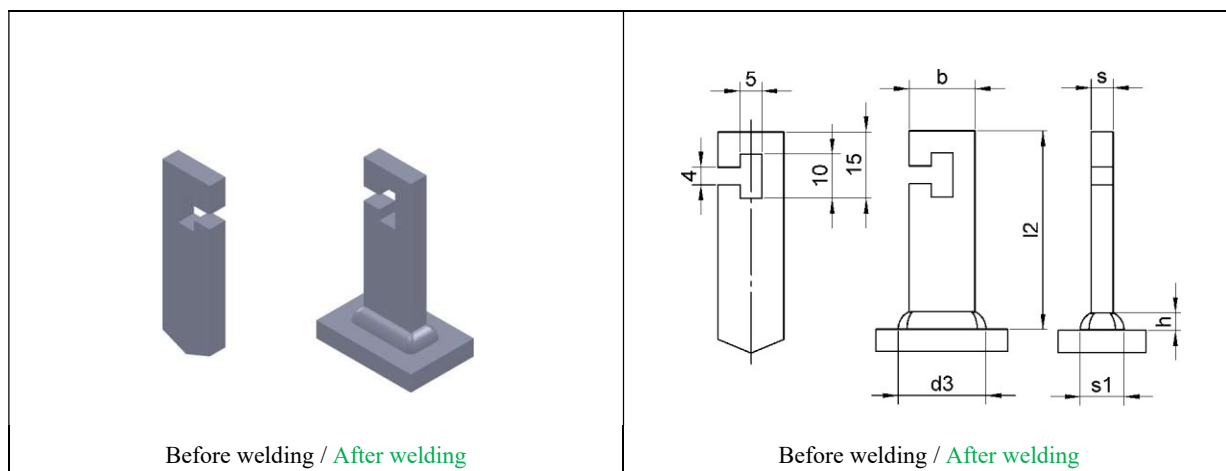

Dimensions						Material (item number)		Ceramic ferrule
b	s	l ₂	d ₃ *	h*	s ₁ *	Steel 4.8	A2-50	
15	3	20-100	18	4	6	On request	On request	KF 15x3
15	5	20-100	20	4	10	On request	On request	KF 15x5
25	3	25-100	28	4	6	On request	On request	KF 25x3
25	5	25-100	28	4	10	On request	On request	KF 25x5

*D₃, H, and S₁ are approximate values.

Rectangular studs (type C) do not normally have a pressed aluminium ball, but can be produced with an aluminium ball on request.

In article number XXX it must be replaced by the respective length of the welding element l₂ (e.g. 030 for 30 mm). Explanations of the materials used can be found in Chapter 3.1.

The available surface treatments are given in chapter 3.1.

Sizes and materials not listed are available upon request.

3.17 Threaded collar stud (KRB type)

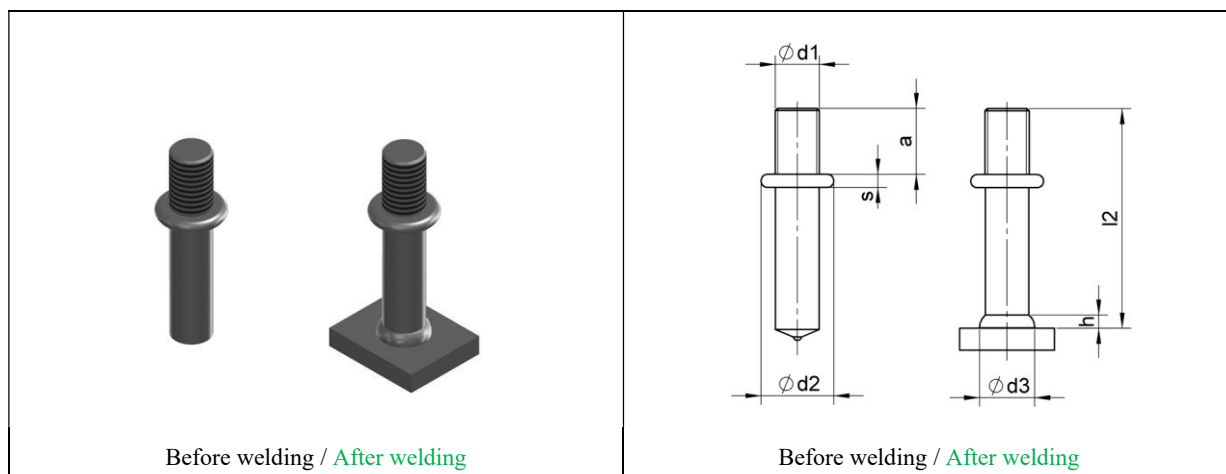

Dimensions							Material (item number)		Ceramic ferrule
d ₁	l ₂	a	d ₂	s	d ₃ *	h'	Steel 4.8	A2-50	
M8	40-100	15	On request	On request	10	3,5	On request	On request	PF 8
M10	40-100	15	On request	On request	12,5	4	On request	On request	PF 10
M12	40-100	15	On request	On request	15,5	4,5	On request	On request	PF 12

*D3 and H are approximate values.

In article number **XXX** it must be replaced by the respective length of the welding element l₂ (e.g. 030 for 30 mm). Explanations of the materials used can be found in Chapter 3.1.

The available surface treatments are given in chapter 3.1.

Sizes and materials not listed available upon request.

3.18 Collar stud (KRS type)

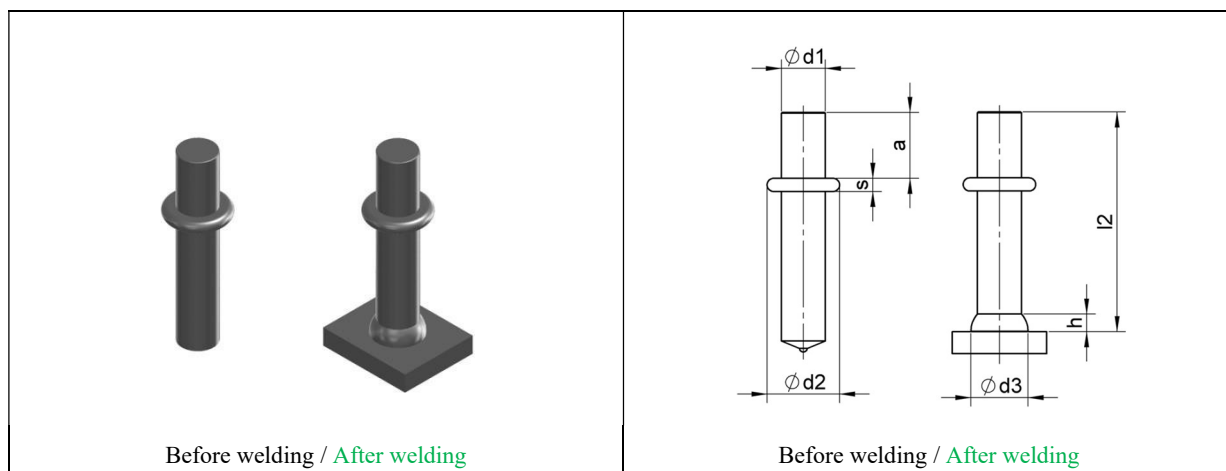

Dimensions							Material (item number)		Ceramic ferrule
d_1	l_2	a	d_2	s	d_3^*	h^*	Steel 4.8	A2-50	
8	30-60	15	On request	On request	11	4	On request	On request	UF 8
10	30-60	15	On request	On request	13	4	On request	On request	UF 10
12	30-60	15	On request	On request	16	5	On request	On request	UF 12

*D3 and H are approximate values.

In article number **XXX** it must be replaced by the respective length of the welding element l_2 (e.g. 030 for 30 mm). Explanations of the materials used can be found in Chapter 3.1.

The available surface treatments are given in chapter 3.1.

Sizes and materials not listed available upon request.

3.19 Threaded stud (type M)

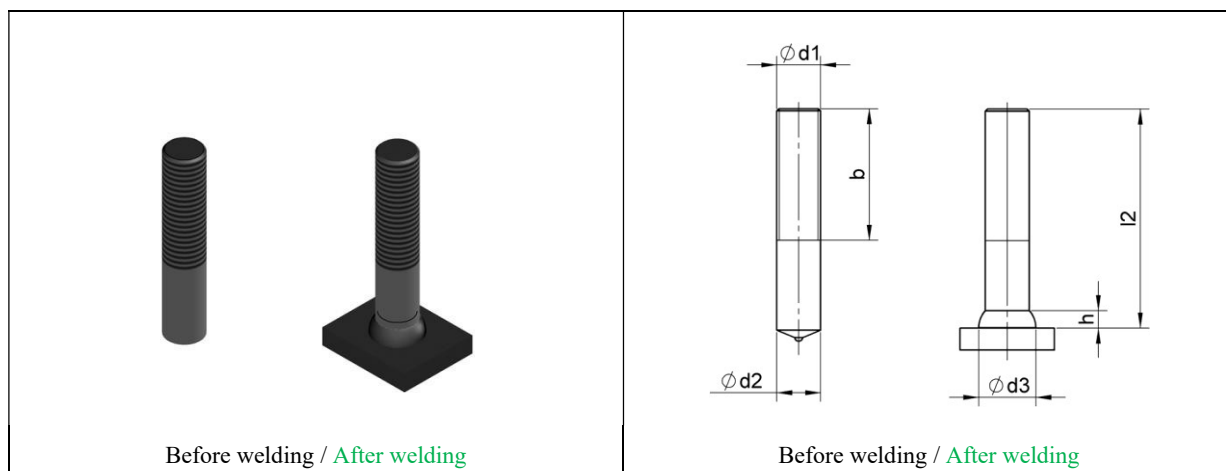

Dimensions						Material (item number)			Ceramic ferrule
d ₁	l ₂	d ₂ -0,1/0,1	b	d ₃ *	h*	Steel 4.8	A2-50	A5-50	
M8	On request	8	On request	11	4	On request	On request	On request	UF 8
M10	On request	10	On request	13	4	On request	On request	On request	UF 10
M12	On request	12	On request	16	5	On request	On request	On request	UF 12
M16	On request	16	On request	21	7	On request	On request	On request	UF 16
M20	On request	20	On request	26	9	On request	On request	On request	UF 20

*D3 and H are approximate values.

In article number **XXX** it must be replaced by the respective welding element length l₂ (e.g. 030 for 30 mm) and **XX** by the respective thread length b.

Explanations of the materials used can be found in Chapter 3.1.

The available surface treatments are given in chapter 3.1.

Sizes and materials not listed available upon request.

3.20 Threaded knock-off stud (type AB-MD, before: AB-MPF)

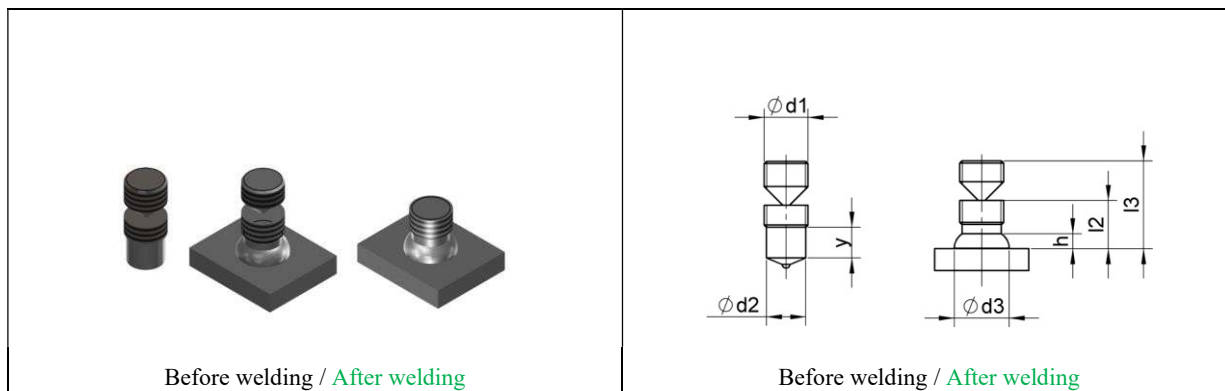

Available sizes and materials and other pin types (e.g. RD, FD) are available upon request.

3.21 Knock-off stud

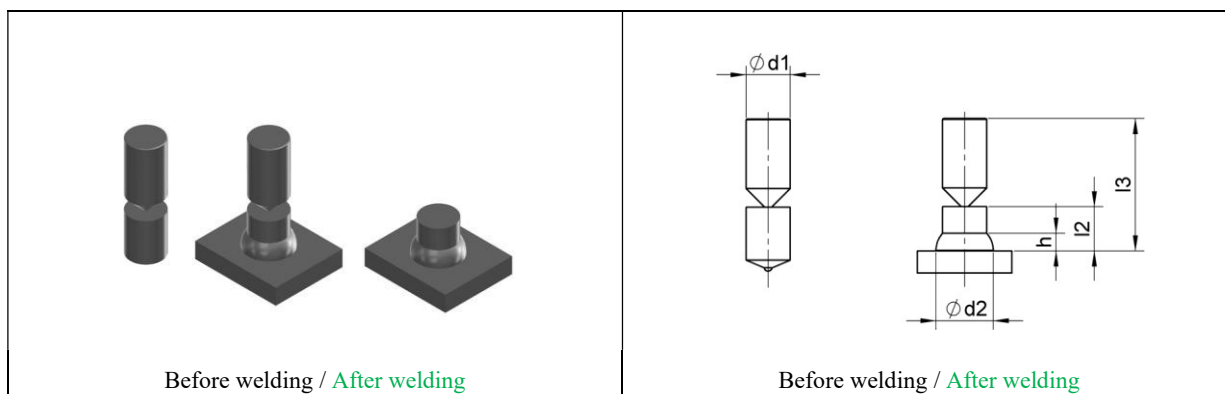

Sizes and materials available on request.

3.22 Curved stud

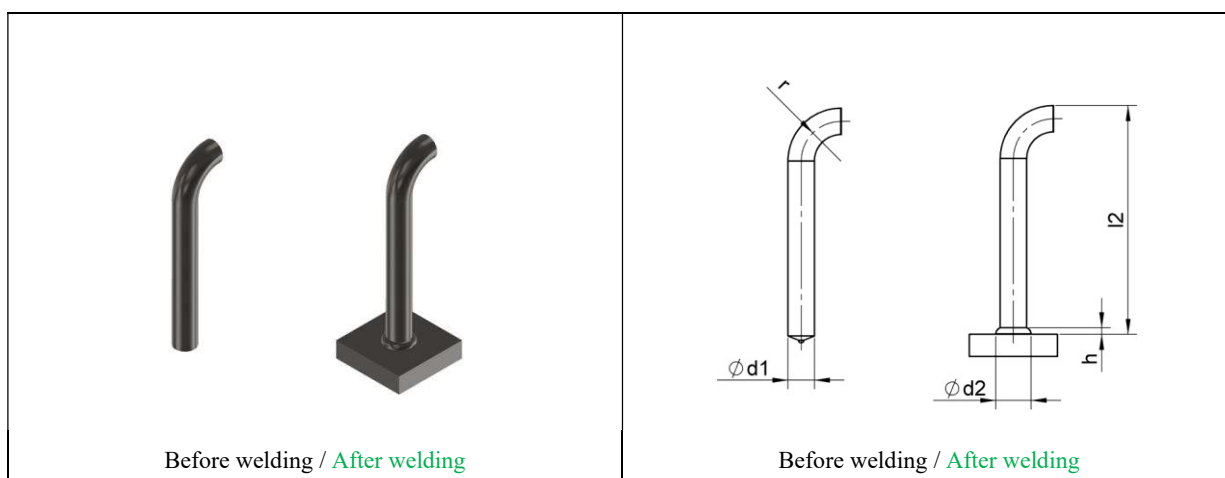

Sizes and materials available on request.

3.23 J-bolt stud

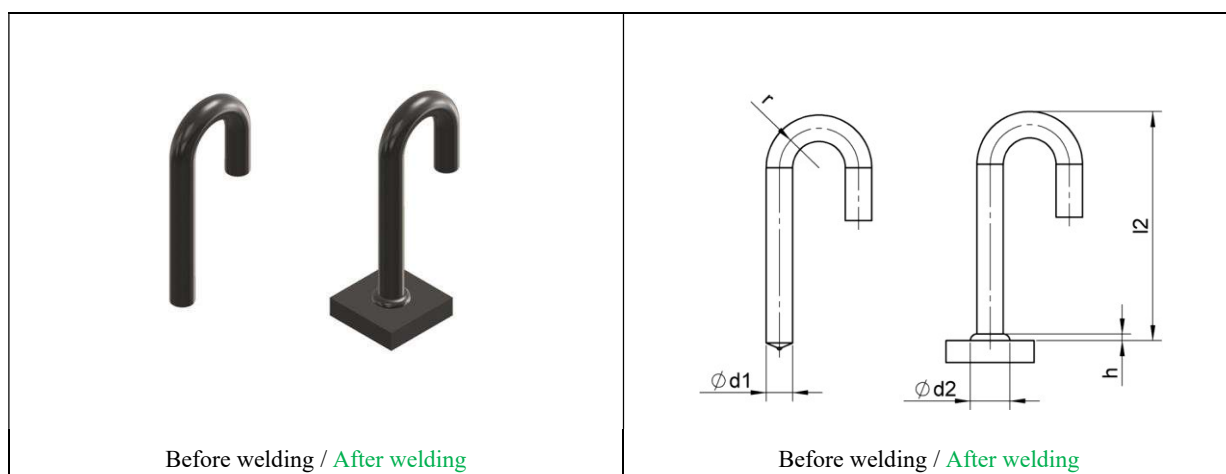

Sizes and materials available on request.

3.24 Bent stud

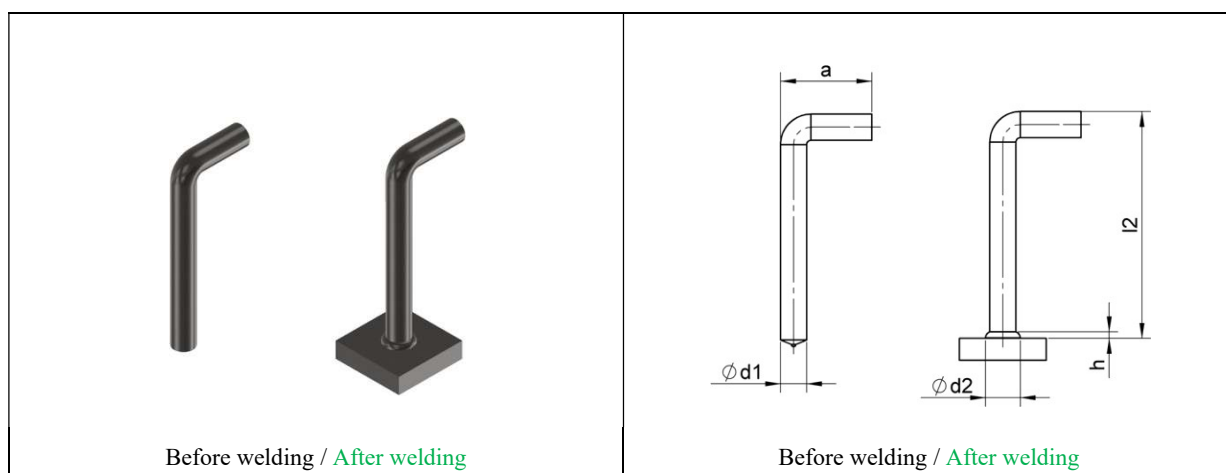

Sizes and materials available on request.

3.25 Stepped stud

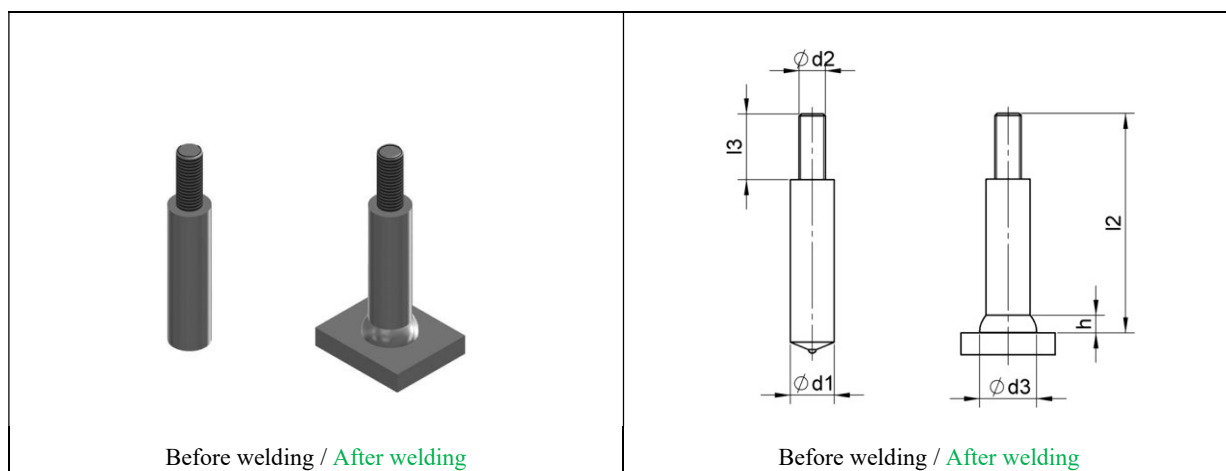

Sizes and materials available on request.

3.26 Locking stud

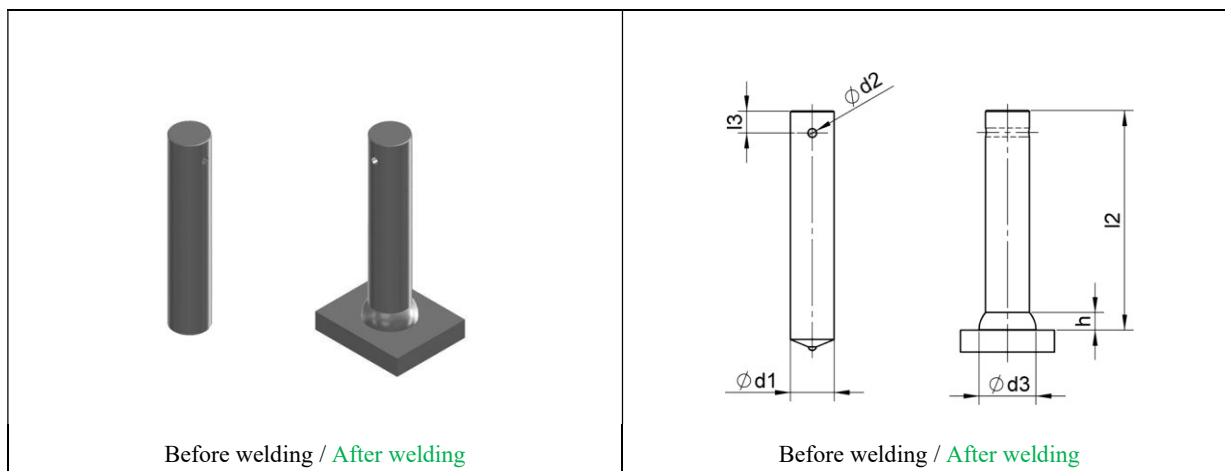

Sizes and materials available on request.

3.27 Cone stud

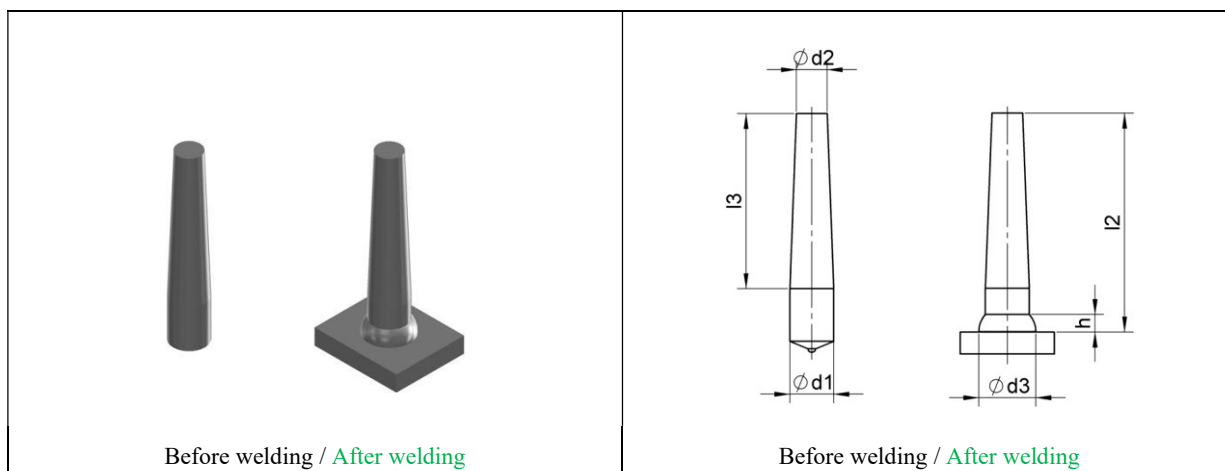

Sizes and materials available on request.

3.28 Flat ended stud

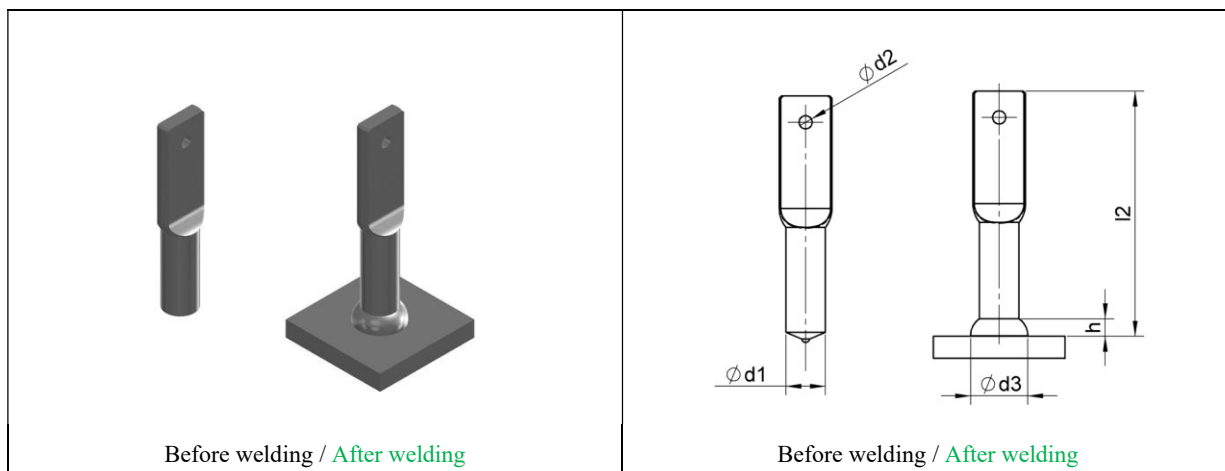

Sizes and materials available on request

3.29 Anti-skid knock-off stud

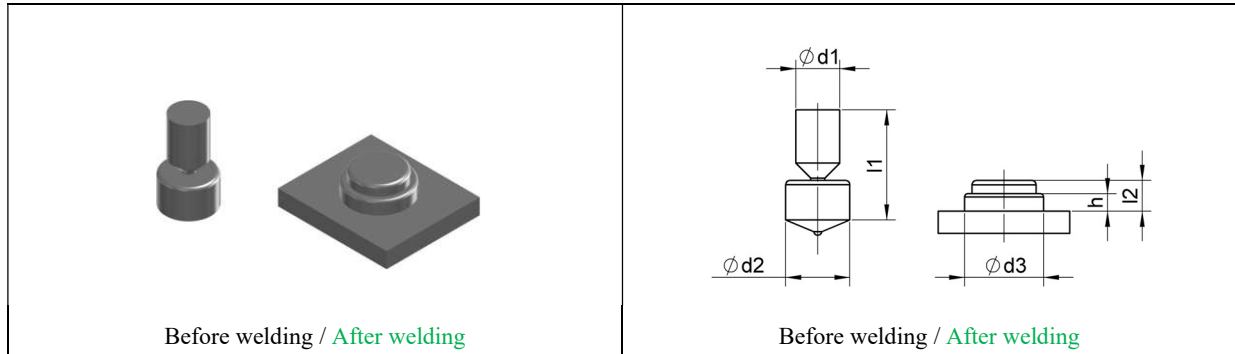

Sizes and materials available on request.

3.30 Ball



Sizes and materials available on request.

3.31 Padded ring for shear connectors

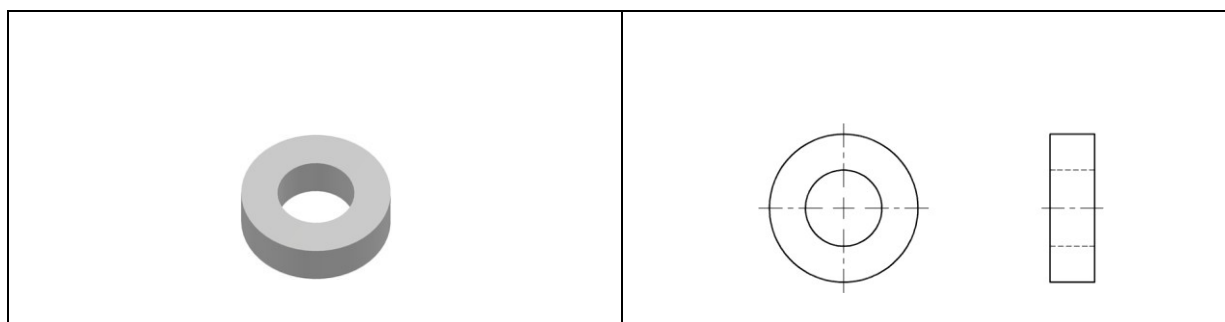

According to our European Technical Assessment ETA-11/0120 it is permitted to use two shear connectors welded one on top of the other by drawn arc stud welding. Thereby a padded ring is to be placed under the head of the first shear connector.

Shear connector diameter (d_1)
10
13
16
19
22
25

Placement of the padded ring:

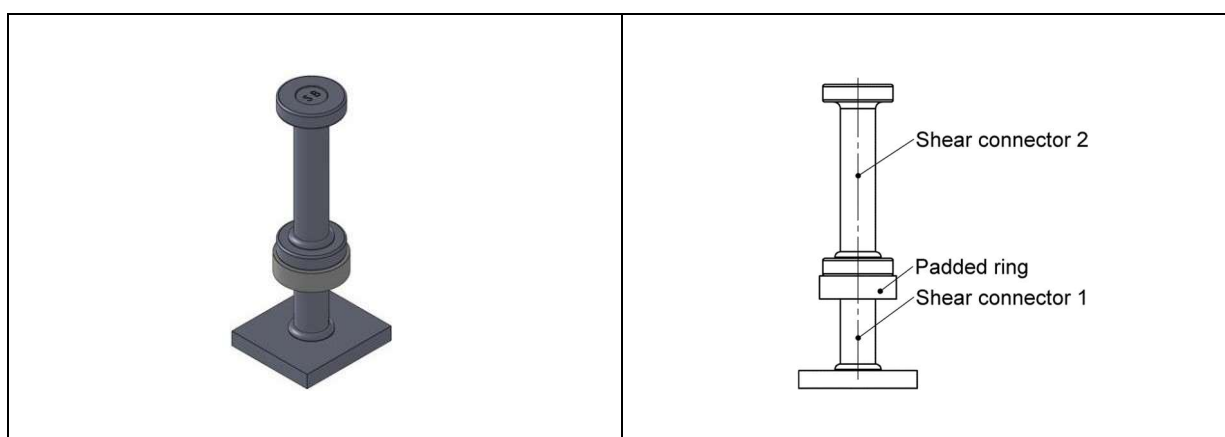

3.32 Ceramic ferrules

1.32.1 Ceramic ferrule for shear connectors, internally threaded studs and non-threaded studs (type UF acc. to DIN EN ISO 13918)



Description	Dimensions			
	$D7$ -0/+0,5	$d8$ -1/+1	$d9$ -1/+1	$h2$
UF 4	4,2	9,5	11,5	≈ 8,7
UF 5	5,2	9,5	11,5	≈ 8,7
UF 6	6,2	9,5	11,5	≈ 8,7
UF 8	8,2	11	15	≈ 8,7
UF 10	10,2	15	17,8	≈ 10
UFN 10	10,2	16,5	20	≈ 9,9
UF 12	12,2	16,5	20	≈ 10,7
UF 13	13,1	20	22,2	≈ 11
UF 16	16,3	26	30	≈ 13
UF 19	19,4	26	30,8	≈ 16,7
UF 20	20,4	26,1	32,8	≈ 14,2
UF 22 flat	22,8	30,7	38,5	≈ 14
UF 22	22,8	30,7	38,5	≈ 18,5
UF 25	26,0	35,5	41	≈ 21

1.32.2 Ceramic ferrule for threaded studs with reduced shaft (type RF acc. to DIN EN ISO 13918)

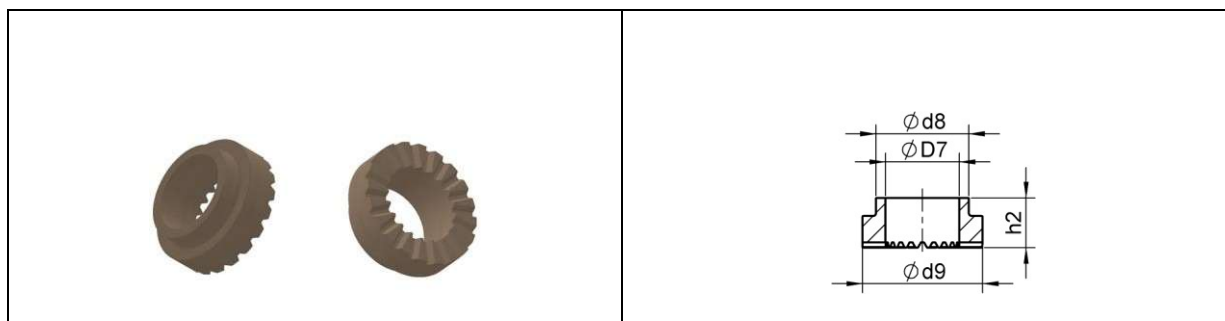

Description	Dimensions			
	$D7$ -0/+0,4	$d8$ -1/+1	$d9$ -1/+1	$h2$
RF 5	5,2	9,5	11,5	≈ 7,9
RF 6	6,2	9,5	12,2	≈ 10
RF 8	8,2	12	15,3	≈ 9
RF 10	10,2	15	18,5	≈ 11,5
RF 12	12,2	17	20	≈ 13
RF 16	16,3	20,5	26,5	≈ 15,3

1.32.3 Ceramic ferrule for threaded studs with reduced shaft, flat form (type RF (flat form) acc. to DIN EN ISO 13918)

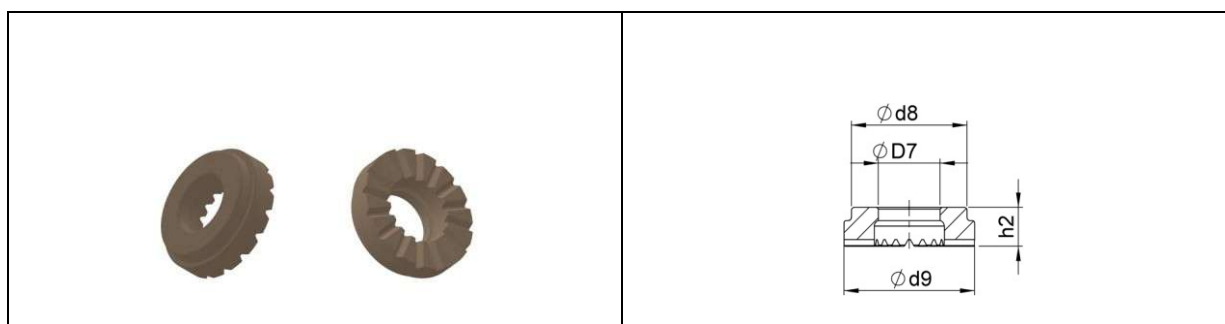

Description	Dimensions			
	$D7$ -0/+0,4	$d8$ -1/+1	$d9$ -1/+1	$h2$
RF 16 (forma piatta)	14	26,2	30	≈ 8,8
RF 20 (forma piatta)	17,5	26,2	32,5	≈ 9

1.32.4 Ceramic ferrule for threaded studs with reduced shaft (type KSR-F)

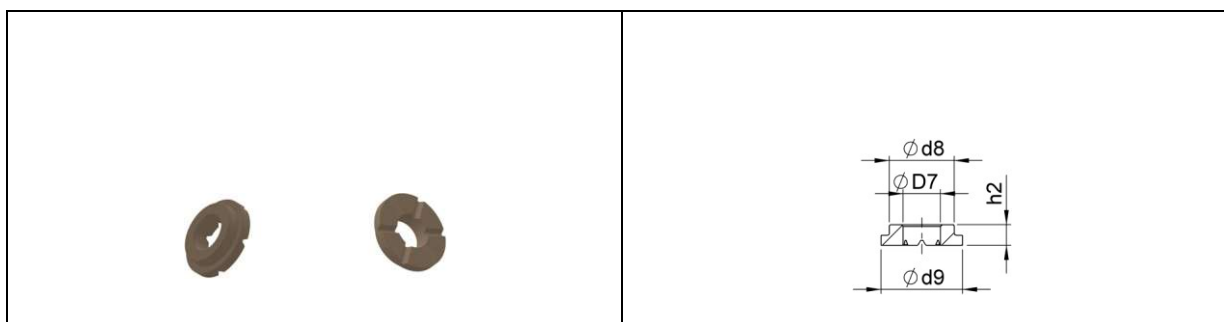

Description	Dimensions			
	D_7 -0/+0,4	d_8 -1/+1	d_9 -1/+1	h_2
KSR-F 8	8,4	14,8	17,8	$\approx 4,7$
KSR-F 10	10,3	14,5	19	$\approx 6,7$

1.32.5 Ceramic ferrule for threaded studs (type MF acc. to DIN EN ISO 13918, before: type KSP-F)

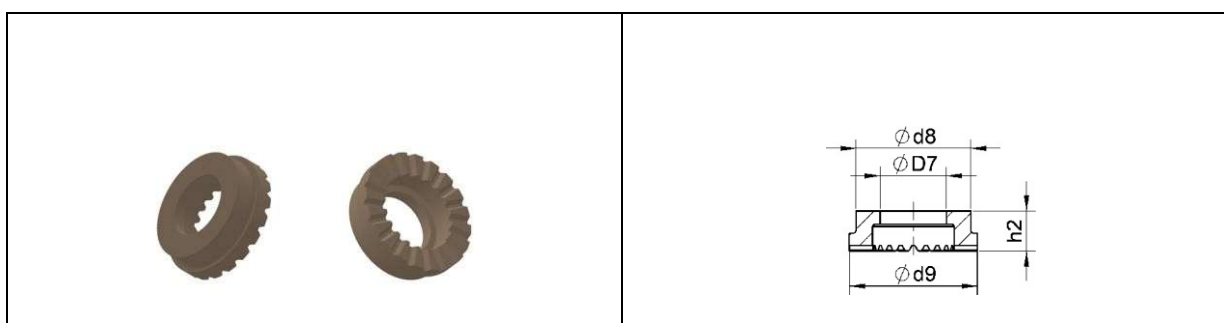

Description	Dimensions			
	D_7 -0,4/+0,4	d_8 -1/+1	d_9 -1/+1	h_2
MF 8	7,8	14,6	17,6	≈ 5
MF 10	9,6	16,5	20	$\approx 5,5$
MF 12	11	20	23,4	$\approx 5,7$
MF 16	15,5	26	29	≈ 9
MF 20	19,3	30,7	33,8	≈ 10

1.32.6 Ceramic ferrule for threaded studs (type PF acc. to DIN EN ISO 13918)

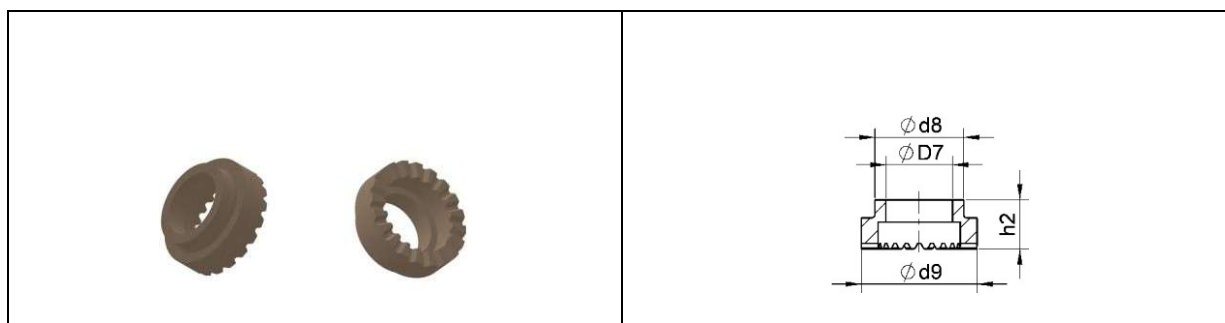

Description	Dimensions			
	D7 -0/+0,5	d8 -1/+1	d9 -1/+1	h2
PF 6	5,6	9,5	11,5	≈ 6,5
PF 8	7,4	11,5	15	≈ 6,5
PF 10	9,2	15	17,8	≈ 6,5
PF 12	11,1	16,5	20	≈ 9
PF 16	15,0	20	26	≈ 11

1.32.7 Ceramic ferrule for internally threaded studs and non-threaded studs (type KSN-F)



Description	Dimensions			
	D7 -0/+0,5	d8 -1/+1	d9 -1/+1	h2
KSN-F 8	8,25	14,8	18,3	≈ 4,8
KSN-F 10	10,25	14,8	17,8	≈ 7,4
KSN-F 12	12,25	20	23,2	≈ 6,3

1.32.8 Permanent ceramic ferrule for pin nails (type K)

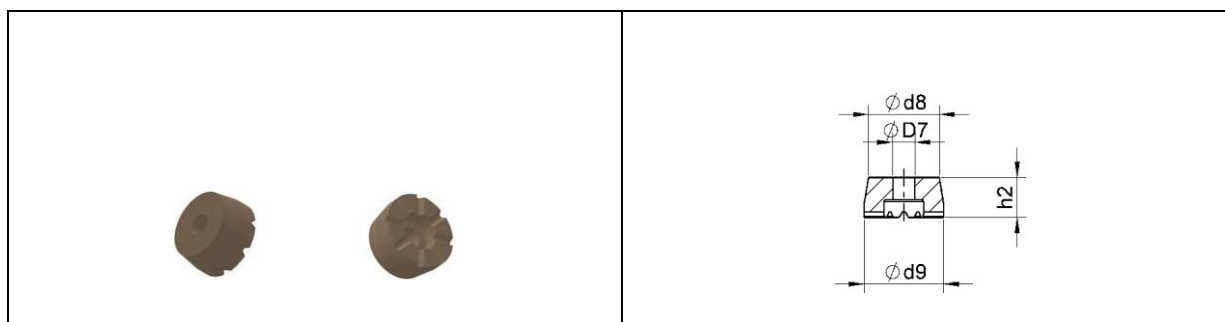

A permanent ceramic ferrule can be used for approx. 100 weldings of insulation pins.

Description	Dimensions			
	D ₇ -0/+0,5	d ₈ -1/+1	d ₉ -1/+1	h ₂
K 5	5,3	16,2	18	≈ 9
K 6	6,3	16,2	18	≈ 9

1.32.9 Ceramic ferrule for rectangular studs (type KF)

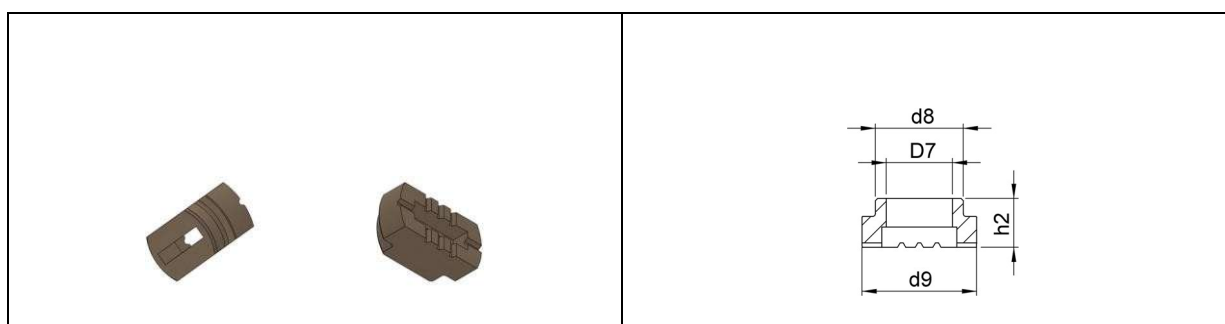

Description	Dimensions			
	D ₇ -0,7/+0,7	d ₈ -1/+1	d ₉ -1/+1	h ₂
KF 15x3	16	20,5	26,5	≈ 11
KF 15x5	16	20,5	26,5	≈ 11
KF 25x3	25,5	30,5	35,5	≈ 13
KF 25x5	25,5	30,5	35,5	≈ 13

3.32.10 Special ceramic ferrule (welding through the metal deck) for shear connectors (type DF according to DIN EN ISO 13918)



Special ceramic ferrule for welding through metal deck (welding of shear connectors through thin, mostly zinc-plated deck sheets onto the top belt of a steel beam).

When welding through zinc-plated deck sheets there are high amounts of degasification through zinc evaporation. The special ceramic ferrule type DF with larger combustion chamber and larger degasification slots considerably improves the welding result.

Description	Dimensions			
	D7 -0/+0,5	d8 -1/+1	d9 -1/+1	h2
DF 16	16,5	25,5	30,2	≈ 17,7
DF 19	20,5	30,8	33,8	≈ 15,2

Sizes not listed available upon request.

3.32.11 Special ceramic ferrule (welding to vertical surfaces) for shear connector (HSG type)

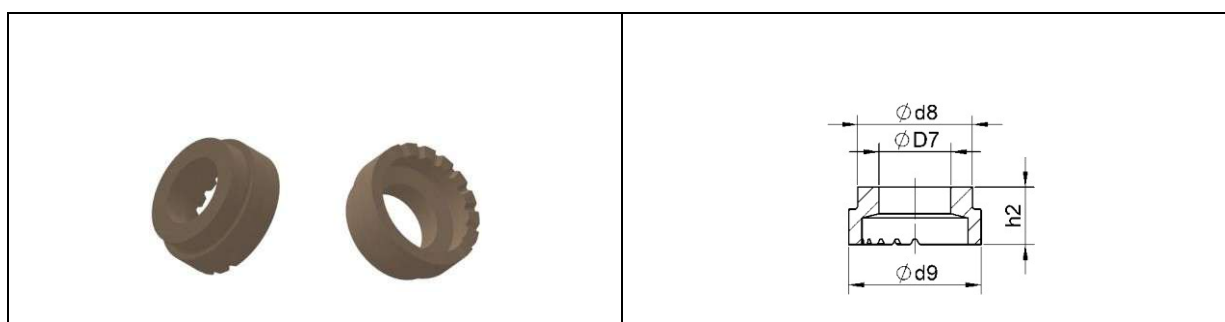

Half-sided closed special ceramic ferrule for welding shear connectors to vertical surfaces.

Description	Dimensions			
	D7 -0/+0,5	d8 -1/+1	d9 -1/+1	h2
HSG 19	19,4	26	30,8	≈ 16,7

Sizes not listed available upon request.

3.32.12 Special ceramic ferrule (welding into angles) for shear connectors (type IWKR)

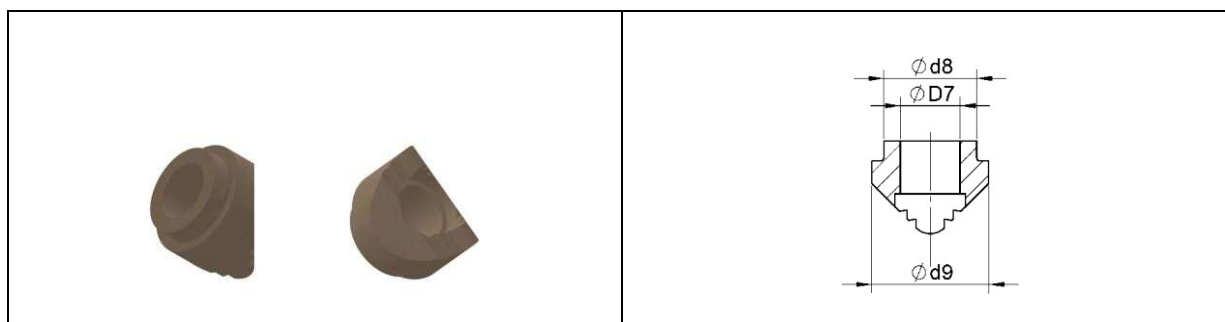

Description	Dimensions		
	D_7 -0/+0,5	d_8 -0,5/+0,5	d_9 -1/+1
IWKR 10	10,4	13	16,5
IWKR 13	13,4	17	20,5

Sizes not listed available upon request.

3.32.13 Special ceramic ferrule (welding onto angles) for shear connectors (type AWKR)

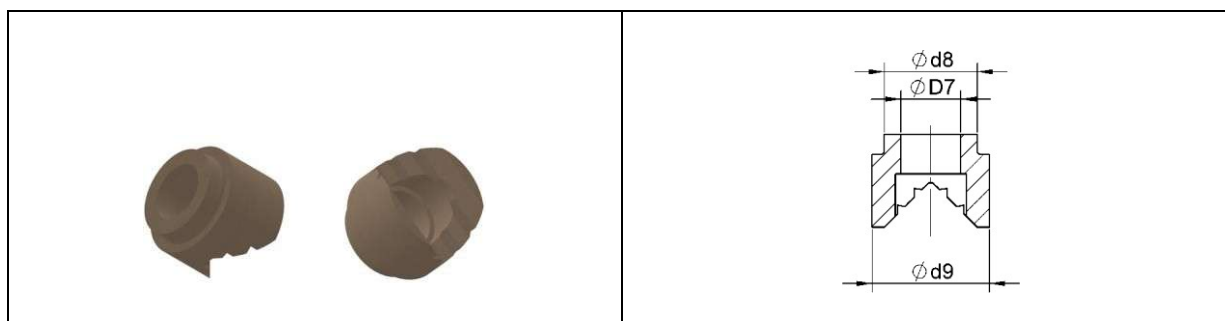

Description	Dimensions		
	D_7 -0/+0,5	d_8 -0,5/+0,5	d_9 -1/+1
AWKR 10	10,4	14,8	18
AWKR 13	13,4	20,5	26,5

Sizes not listed available upon request.

3.32.14 Special ceramic ferrule (welding to convex surfaces) for shear connectors (type ABKR)

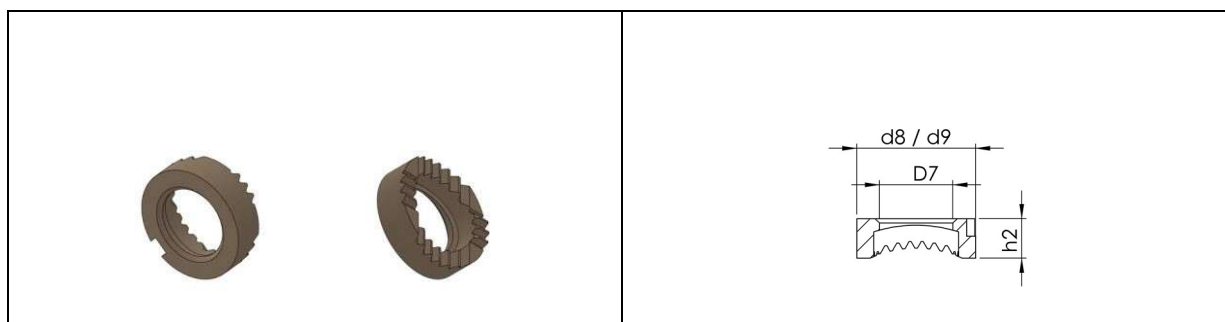

Special ceramic ferrule for welding shear connectors to convex surfaces (tubes etc.).

Description	Dimensions			
	D ₇ -0/+0,5	d ₈ -1/+1	d ₉ -1/+1	h ₂
ABKR 16	16,3	26,5	26,5	≈ 9
ABKR 19	19,4	29,5	29,5	≈ 9

Sizes not listed available upon request.

3.33 Fixing accessories

3.33.1 Threaded plate

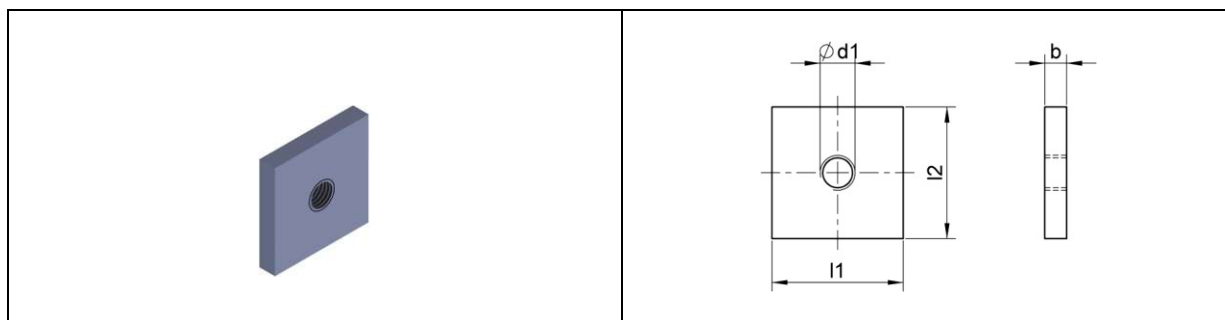

Sizes and materials available on request.

3.33.2 Disc nut

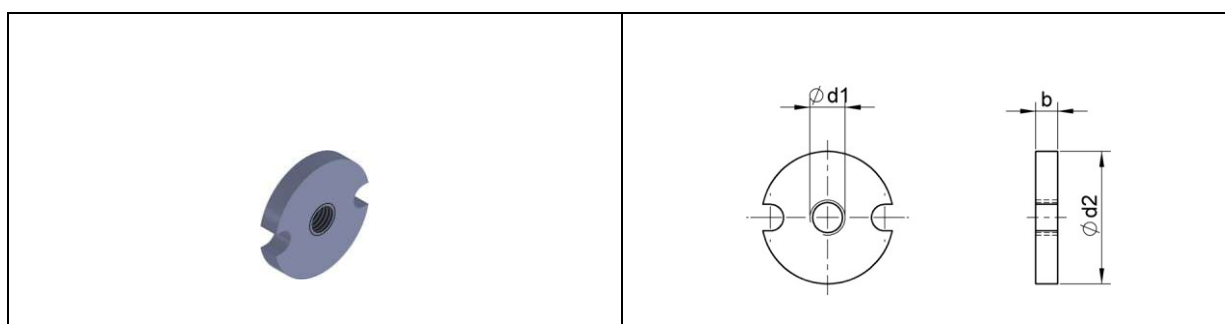

Sizes and materials available on request.

3.34 Silicone cover caps

Silicone cover caps protect the mechanically important areas of the welding elements during painting and powder coating, as well as during the combustion process (permanent temperature $\leq 210^{\circ}\text{C}$, short temperature $\leq 300^{\circ}\text{C}$).

3.34.1 Silicone cover caps for threaded studs and non-threaded studs

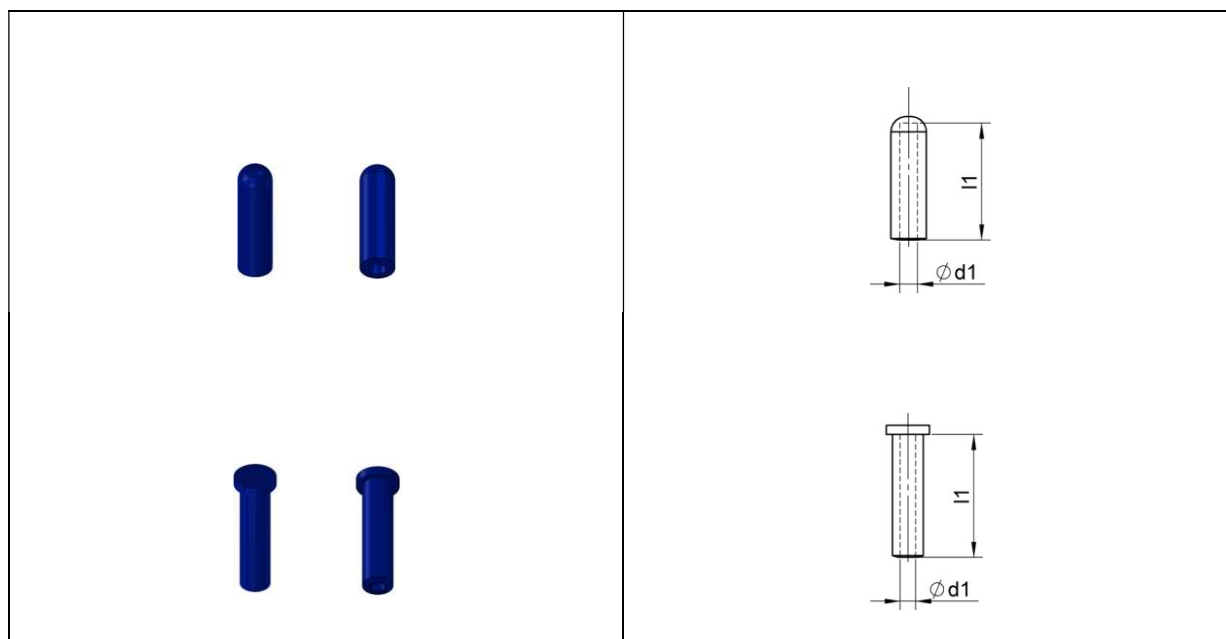

Sizes available on request.

3.34.2 Silicone cover caps for internally threaded studs

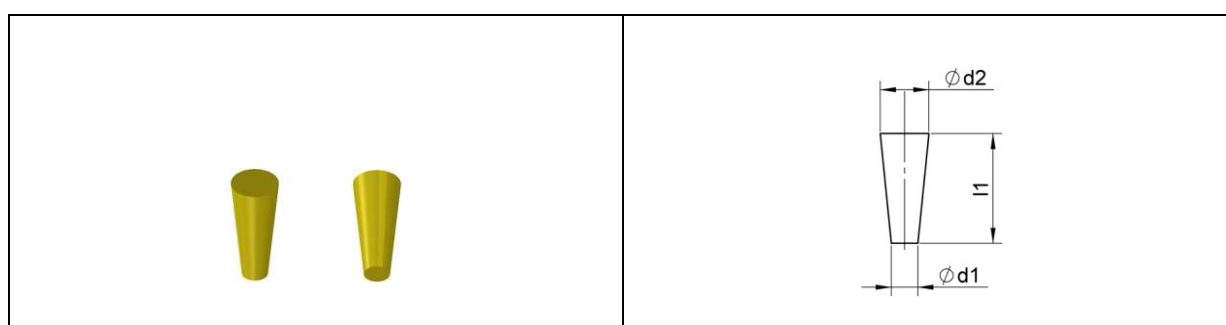

Sizes available on request.

4. Welding studs for short cycle stud welding

4.1 Technical Information

Materials

We produce our welding studs from the following materials with excellent weldability:

Material group/strength class	Norm
Steel 4.8	ISO 898-1
A2-50, A2-70A5-50, A5-70	ISO 3506-1

The material specifications are in accordance with DIN EN ISO 13918 and DIN EN ISO 14555. For welding studs of other materials, please send us your inquiry or contact us.

On request, the material properties can be checked with an inspection document (test report, inspection certificate) in accordance with DIN EN 10204.

We are happy to inform you about weldability to different base materials and welding parameters.

Dimensions

The dimensions of the weld studs are shown in the measurement tables (all dimensions are in mm). All standardised weld studs comply with DIN EN ISO 13918. Non-standardised weld studs are supplied in accordance with DIN EN ISO 13918. Special welding elements, not described, are supplied on request.

Dimensions not listed in the measurement tables are provided upon request.

Surface protection

As a rule, our welding studs made of 4.8 steel are supplied with an electrolytic copper plating of 4-8 μm (according to DIN EN ISO 4042) as corrosion protection. Other surface treatments are possible on request.

Threads

The pin threads are cold-rolled (tolerance limit 6g). For surface-treated studs, the tolerance limit of 6h can be reached. On request, we supply studs with special threads.

Stud Flange

Short-cycle weld studs have a cold-formed flange that is strictly tolerated. The diameter of the flange is always larger than the outer diameter of the welding element (see drawings and measurement tables below). The flange increases the surface area of the stud. As a result, the stresses at the welding point are reduced and this results in a higher quality of the welded joint.

On request, weld studs with flange sizes other than those listed and weld studs without flange can be supplied. However, we can only recommend the limited use of flangeless weld studs, depending on the requirements of the welded joint. Please contact us for this.

Weld Face

Short-run weld studs have a cold-formed tapered weld side with tightly controlled dimensions. The exact dimensions of the weld profile are crucial for achieving correct welding results.

Stud Welding Gun Accessories

Accessories for welding guns must be adapted to the welding element.

4.2 Threaded stud (type PS acc.to DIN EN ISO 13918)

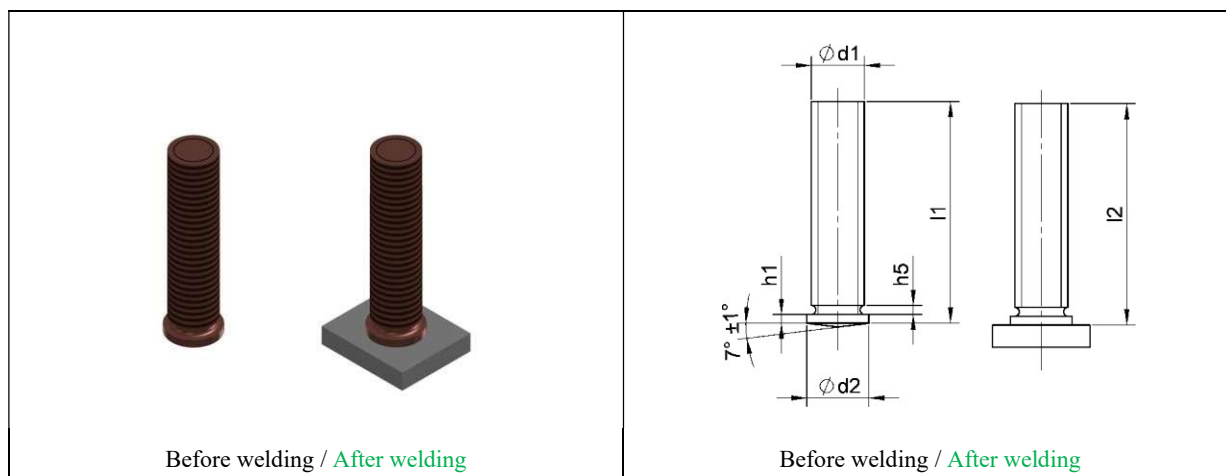

Dimensions					Material (item number)		
d_1	l_1 +0,6	d_2 $\pm 0,2$	h_5 max.	h_1	Steel 4.8 copper-plated	A2-50	A5-50
M3	6-30	4	0,6	0,7-1,4	On request	On request	On request
M4	6-40	5	0,6	0,7-1,4	On request	On request	On request
M5	6-45	6	1,0	0,7-1,4	On request	On request	On request
M6	8-60	7	1,0	0,7-1,4	On request	On request	On request
M8	10-60	9	1,5	0,8-1,4	On request	On request	On request
M10	15-60	11	2,0	0,8-1,4	On request	On request	On request

*L2 (length after welding) depends on L1 and welding energy.

In article number **XXX** it must be replaced by the respective length of the welding element l1 (e.g. 030 by 30 mm). Explanations of the materials used are given in chapter 4.1.

Sizes and materials not listed available upon request.

4.3 Internally threaded stud (type IS acc. to DIN EN ISO 13918)

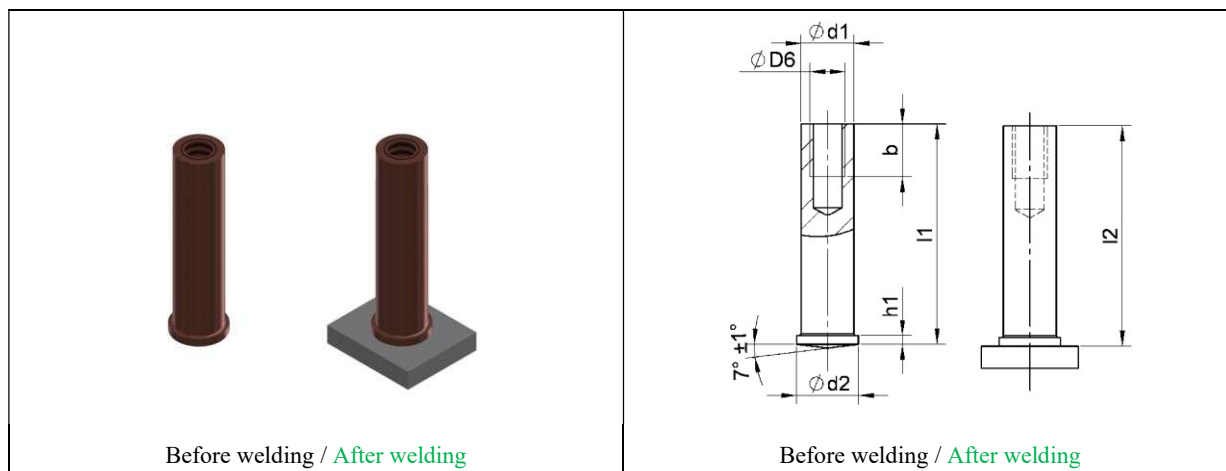

Dimensions						Material (item number)	
d ₁ ±0,1	l ₁ +0,6	D ₆	b min. +2P ¹	d ₂ ±0,2	h ₁	Steel 4.8 copper-plated	A2-50
5	6-30	M3	5 (4 ²)	6,0	0,7-1,4	On request	On request
6	8-40	M4	5	7,0	0,7-1,4	On request	On request
7,1	10-40	M5	6	9,0	0,8-1,4	On request	On request
8	15-40	M6	10	9,0	0,8-1,4	On request	On request

1P = thread pitch according to DIN 13-1

² for L₂ < 8 mm

*L₂ (length after welding) depends on L₁ and welding energy.

In article number **XXX** it must be replaced by the respective length of the welding element l₁ (e.g. 030 by 30 mm). Explanations of the materials used are given in chapter 4.1.

Sizes and materials not listed available upon request.

4.4 Non-threaded stud (type US acc.to DIN EN ISO 13918)

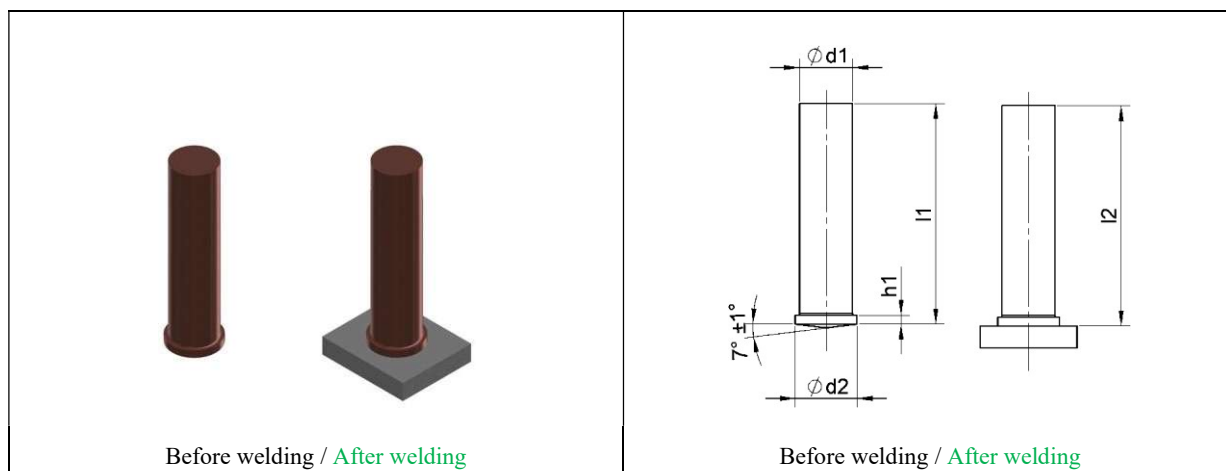

Dimensions				Material (item number)		
d ₁	l ₁ +0,6	d ₂ ±0,2	h ₁	Steel 4.8 copper-plated	A2-50	A5-50
3	6-30	4	0,7-1,4	On request	On request	On request
4	6-40	5	0,7-1,4	On request	On request	On request
5	6-45	6	0,7-1,4	On request	On request	On request
6	8-60	7	0,7-1,4	On request	On request	On request
7,1	10-60	9	0,8-1,4	On request	On request	On request
8	15-60	9	0,8-1,4	On request	On request	On request

*L2 (length after welding) depends on L1 and welding energy.

In article number **XXX** it must be replaced by the respective length of the welding element l1 (e.g. 030 by 30 mm). Explanations of the materials used are given in chapter 4.1.

Sizes and materials not listed available upon request.

4.5 Fir tree stud

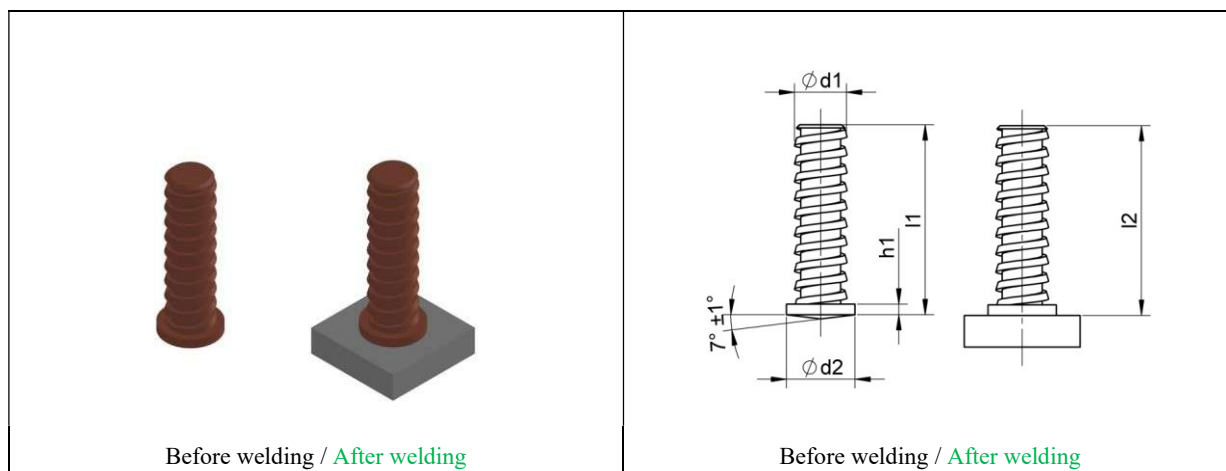

Dimensions				Material (item number)	
d1	l1 +0,6	d2 ±0,2	h1	Steel 4.8 copper-plated	A2-50
5	9	6	0,7-1,4	On request	On request
5	14,2	6	0,7-1,4	On request	On request
5	18	6	0,7-1,4	On request	On request
5	25	6	0,7-1,4	On request	On request

*L2 (length after welding) depends on L1 and welding energy.

Explanations of the materials used are given in chapter 4.1.

Sizes and materials not listed available upon request.

4.6 Threaded stud with self-cleaning groove (self-tapping)

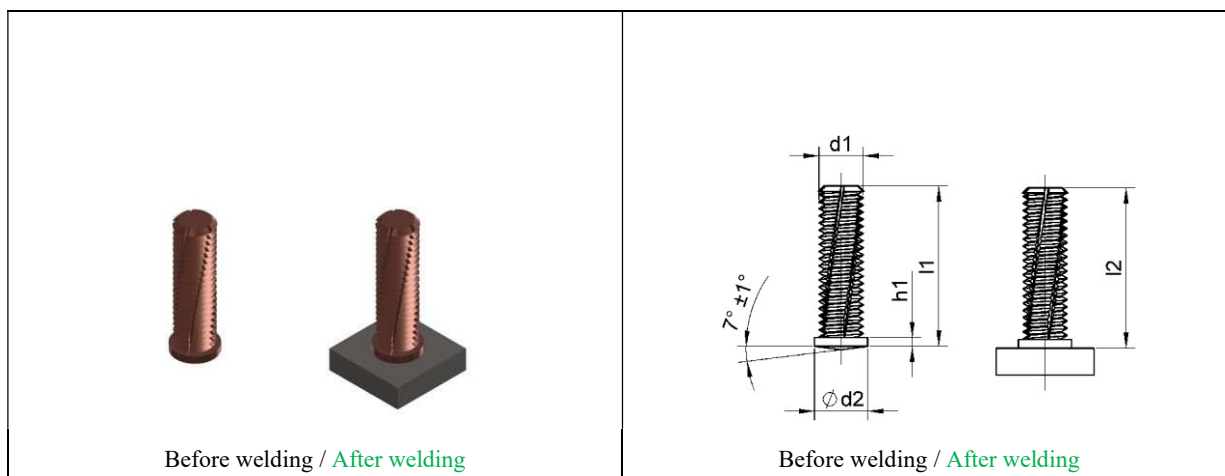

Dimensions				Material (item number)	
d ₁	l ₁ +0,6	d ₂ ±0,2	h ₁	Steel 4.8 copper-plated	A2-50
M4	On request	5	0,7-1,4	On request	On request
M5	On request	6	0,7-1,4	On request	On request
M6	On request	7	0,7-1,4	On request	On request
M8	On request	9	0,8-1,4	On request	On request

*L2 (length after welding) depends on L1 and welding energy.

In article number XXX it must be replaced by the respective length of the welding element l1 (e.g. 030 by 30 mm). Explanations of the materials used are given in chapter 4.1.

Sizes and materials not listed available upon request.

4.7 Silicone cover caps

Silicone cover caps protect the mechanically important areas of the welding elements during painting and powder coating, as well as during the combustion process (permanent temperature $\leq 210^{\circ}\text{C}$, short temperature $\leq 300^{\circ}\text{C}$).

4.7.1 Silicone Cover Caps for Threaded Studs and Non-Threaded Studs

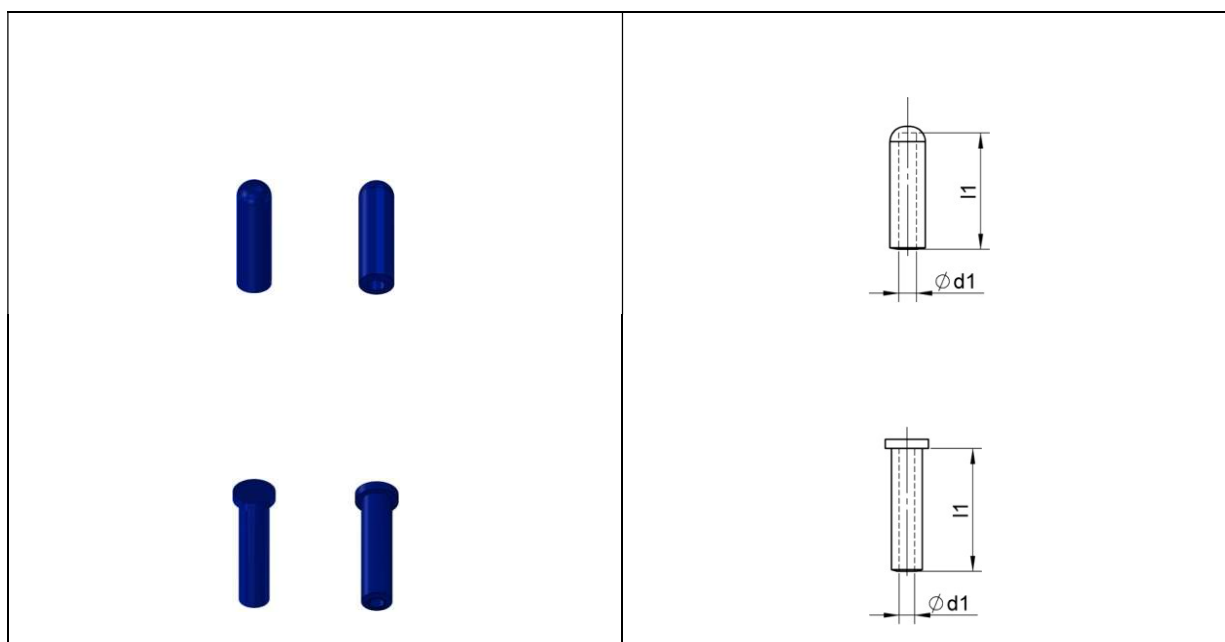

Sizes available on request.

4.7.2 Silicone cover caps for internally threaded studs

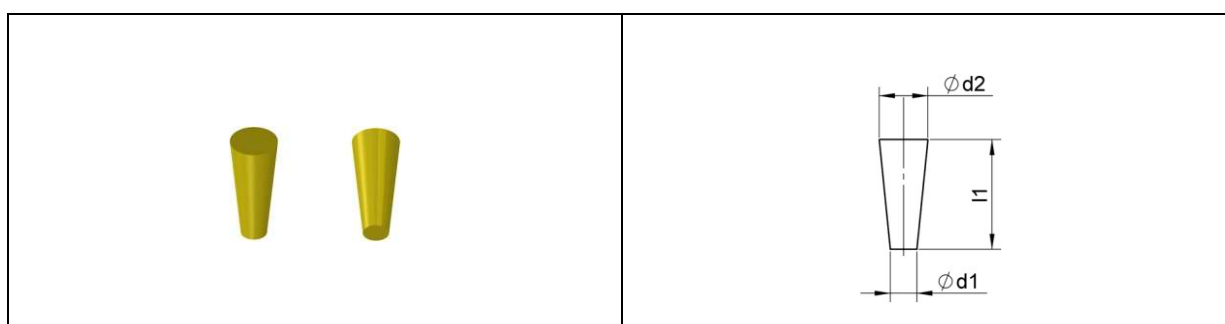

Sizes available on request.



The company A.T.S. S.n.c. was founded in 1983 initially as a technical assistance in the field of spot welding, subsequently, thanks to the numerous requests of customers, the license for the marketing of welding systems and related spare parts was acquired.

Today A.T.S. S.r.l., with the help of valid collaborators who systematically attend training and refresher courses, is at the forefront in the supply of equipment and materials in the catalog so called standards. It is also specialized in the production of parts to customer specifications, and any other object on request related to the field of spot welding, pin welding and fixing.

All the equipment supplied is guaranteed by the assistance of specialized internal technical personnel who make use of certified instruments.

On 22/07/2002 the company obtained with great satisfaction and pride the UNI EN ISO 9001:2000 Quality Management System certification, adapting to the UNI EN ISO 9001:2008 standard from 01/07/2009 and subsequently to the new UNI EN ISO 9001:2015 standard from 03/04/2018.

The main focus is on the customer, on the ability to recognize their needs and expectations, in order to be in line with market expectations trying to achieve the set objectives through continuous improvement.



CONTACTS

ADDRESS: A.T.S. s.r.l. 40023 Castel Guelfo (BOLOGNA) – Via del Mangano, 4/A

TELEPHONE: +39 0542.67.04.27

EMAIL: info@atslamberti.com

SITE: www.atsslamberti.com

P.IVA: 00824841209 **C.F.** 04169740372

