



A.T.S. S.R.L.

Via Del Mangano 4/A 40023 Castel Guelfo (Bo)

Tel: 0542/670427 Fax: 0542/670437

P.IVA: 00824841209 C.F. e REG.IMPR: 04169740372

Sito Web: [http:// www.atslamberti.com](http://www.atslamberti.com) E-mail: info@atslamberti.com

SINCERT



REG. N. 3.023-A
UNI EN ISO 9001:2008

PRESSA PER INSERTI AUTOAGGANCIANTI

PICCOLA NELLE DIMENSIONI, MA GRANDE NELLE PRESTAZIONI. COSTRUITA CON IL MEGLIO DELLA COMPONENTISTICA MONDIALE PER ESSERE AFFIDABILE NEL TEMPO.

LA SUA VERSATILITA', FACILITA' D'USO E DI MANUTENZIONE LA RENDONO INDISPENSABILE PER RISOLVERE IN SICUREZZA TUTTI I PROBLEMI LEGATI ALL'UTILIZZO DI INSERTI AUTOAGGANCIANTI.

VERSATILITA'

La compattezza e la geometria della struttura consentono di posizionare inserti con forze variabili fino a 6.000 Kg. Su una Vs. tipologia di sagome.

SICUREZZA

L'utilizzo di carrelli mobili consente di ridurre la distanza tra matrice e punzone ai valori prescritti dalle normative di sicurezza.

QUALITA'-PREZZO

Caratteristica che siamo certi apprezzare già dal primo incontro



FLEXIBILITY

Compactness and geometry of the structure allow to install inserts with a force that goes up to 6,000 kg for a vast numbers/types of shapes.

SAFETY

Moving saddles reduce the distance between the anvil and the punch within the values of safety.

QUALITY to PRICE rate

This is a feature you will appreciate at the very first encounter.



A.T.S. S.R.L.

Via Del Mangano 4/A 40023 Castel Guelfo (Bo)

Tel: 0542/670427 Fax: 0542/670437

P.IVA: 00824841209 C.F. e REG.IMPR: 04169740372

Sito Web: [http:// www.atslamberti.com](http://www.atslamberti.com) E-mail: info@atslamberti.com

SINCERT



REG. N. 3.023-A

UNI EN ISO 9001:2008

ACCESSORIO N° 2

ACCESSORY N° 2

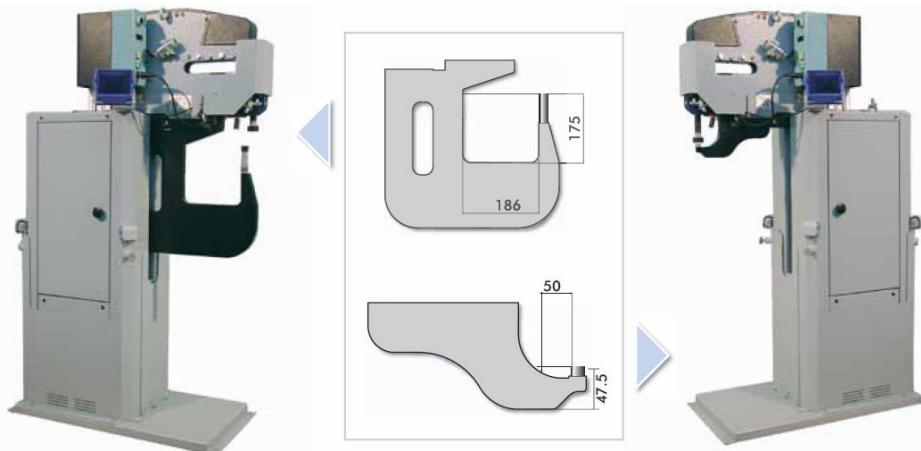

SAGOME INTERCambiabili - INTERCHANGEABLE FRAMES

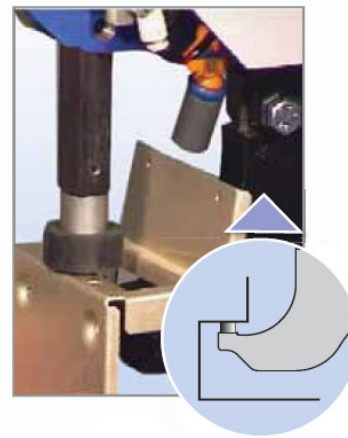
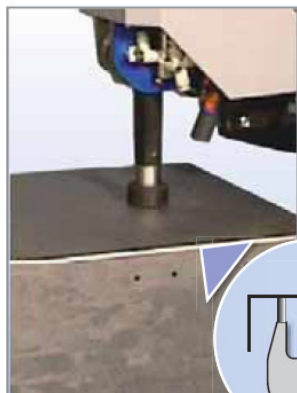

L'accessorio n° 2 con le sue sagome intercambiabili, realizzabili anche su disegno del cliente, permette di applicare inserti in scatolati e laminati metallici dalle forme più varie.

Accessory n° 2, with its changeable frames that can be made also for your drawings, enables you to insert fasteners in box-shaped pieces and in the most varied shapes of metal sheets.

ACCESSORIO N° 1

ACCESSORY N° 1

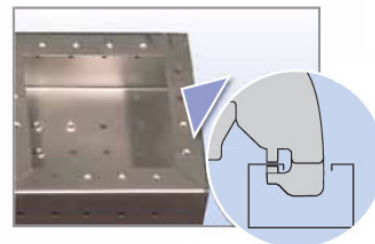

L'accessorio n° 1 permette di applicare inserti in scatolati e laminati metallici la cui forma ricorda una "C".

Accessory n° 1 enables you to insert fasteners in "C" – like pieces.



A.T.S. S.R.L.

Via Del Mangano 4/A 40023 Castel Guelfo (Bo)

Tel: 0542/670427 Fax: 0542/670437

P.IVA: 00824841209 C.F. e REG.IMPR: 04169740372

Sito Web: [http:// www.atslamberti.com](http://www.atslamberti.com) E-mail: info@atslamberti.com

SINCERT



REG. N. 3.023-A

UNI EN ISO 9001:2008

Misure ed ingombri - *Dimension*

	Senza Basamento – <i>Without Base</i>	Con Basamento – <i>With Base</i>
Peso – <i>Weight</i>	50 kg – (110 lbs)	93 kg – (204,6 lbs)
Altezza – <i>Height</i>	311 mm – (12,24’’)	1295 mm – (50,98’’)
Profondità – <i>Depth</i>	516 mm – (20,31’’)	730 mm – (28,74’’)
Larghezza – <i>Width</i>	250 mm – (9,84’’)	380 mm – (14,96’’)

Caratteristiche Tecniche – *Technical Data*

Azionamento – <i>Drive</i>	Aria compressa – <i>compressed air 6-10 bar</i>
Alimentazione – <i>Power</i>	220 v / 100 w (opt. 110 v / 100 w single phase)
Forza di compressione – <i>Force range</i>	280 kg – 6.000 kg – (600 lbs to 14.000 lbs)
Massimo spessore – <i>MAX sheet thickness</i>	3 mm – (0,12’’)

Accessorio n° 2 - *Accessory n° 2*
(mm)

Accessorio n°1 - *Accessory n°1*
(mm)

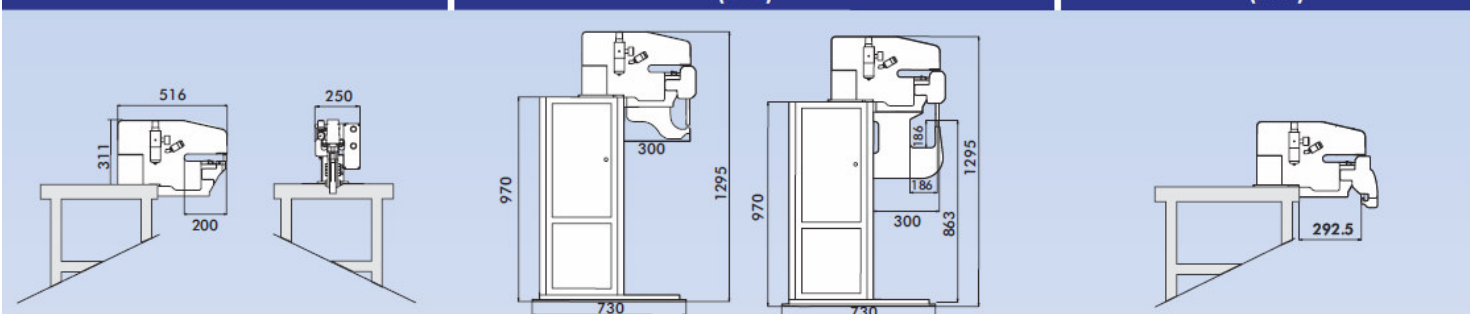

Con accessorio n. 2 basamento obbligatorio
In order to utilize Accessory No. 2, it is mandatory to install the press on its stand.

OPTIONALS

Basamento fisso (mm)
Fixed Stand

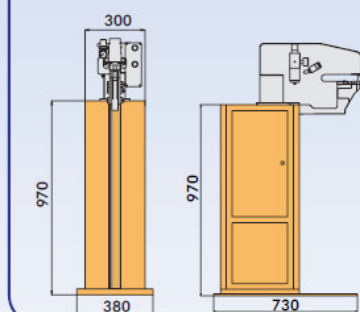

Lampada
Lamp

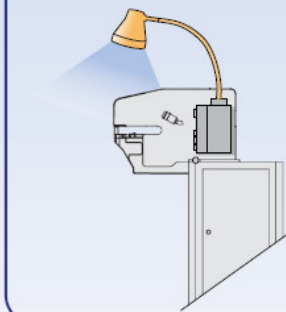

Basamento sollevabile (mm)
Risable Stand

