



# TECNA®



Advanced Resistance Welding Systems and Balancers

3660E-tech  
3670E-tech

-  SISTEMI DI SALDATURA A MEDIA FREQUENZA PER IMPIANTI DI FINE LINEA
-  WELDING SYSTEMS DEDICATED TO THE END-OF-LINE PLANTS
-  MF- SCHWEISS-SYSTEME FÜR FERTIGUNGSANLAGEN



UNITA' DI CONTROLLO TE760  
TE760 WELDING CONTROL UNIT  
SCHWEISS-STEUERUNG TE760

The most advanced resistance welding machines

[www.tecna.net](http://www.tecna.net)



## 3660E-tech | 3670E-tech

Le E-tech sono i nuovi sistema di saldatura TECNA dedicati agli impianti di fine linea. La versatilità della macchina assieme alle ottime caratteristiche tecniche, date dal controllo di saldatura TE760 applicato, danno vita ad una macchina che si colloca tra il mondo della carrozzeria e quello industriale in grado di garantire un'ottima qualità di saldatura in ambienti altamente produttivi.

### CARATTERISTICHE PRINCIPALI

- Pinza «C» art.8669/SK completamente raffreddata che sviluppa una forza di 450 daN a 8bar.
- Le pinze di saldatura sono collegate alla macchina tramite 2 cavi raffreddati extraflessibili di lunghezza 2400mm.
- Il sistema di saldatura è equipaggiato anche di raffreddamento a bordo macchina.
- Le macchine sono corredate di asta e bilanciatore per la sospensione delle pinze.
- Comunicazione tramite porta USB.
- Controllo di saldatura TE760 di derivazione industriale.
  - Programmazione semplificata tramite 9 tasti e display grafico retroilluminato.
  - Comando ad inverter con IGBT a media frequenza.
  - Memorizzazione di 150 programmi di saldatura, fino a 4 richiamabili dall'esterno.
  - Fino a 15 parametri programmabili per ogni programma.
  - Funzioni di salita corrente, discesa corrente, pulsazioni, pre-saldatura, post-saldatura e regolazione dei tempi di saldatura con risoluzione 1 mS.
  - Visualizzazione dell'RMS della corrente di saldatura e della percentuale di utilizzo della macchina,
  - 2 modalità di funzionamento: corrente costante e FIX.
  - Limiti in corrente e percentuale di utilizzo dell'inverter.
  - Funzione incrementale per compensare l'usura degli elettrodi con curve programmabili.
  - Ciclo singolo e automatico.
  - Funzione di SALDA / NON SALDA.
  - Autoregolazione alla frequenza di rete 50/60 Hz.
  - Lingua selezionabile: italiano, inglese, francese, tedesco, spagnolo, svedese e portoghese.
  - Possibilità d'aggiornamento del firmware del controllo.
  - Sequenza programmi.
  - Possibilità di consultare alcune tabelle di saldatura.

### REALIZZAZIONE VERSIONI «CF»

A richiesta la macchina può essere equipaggiata con:

Pinza «X» art.8678/SK completamente raffreddata che sviluppa una forza di 610 daN a 6 bar. (Versione CF01)

Pinza «X» art.8677/SK completamente raffreddata che sviluppa una forza di 240 daN a 8 bar. (Versione CF02)

Monopunto art.3581K completamente raffreddata. (Versione CF03)

## 3660E-tech | 3670E-tech

The E-tech are the new TECNA's welding systems dedicated to the end-of-line plants. The versatility of the machine together with the excellent technical features given by the TE760 welding control unit, create a machine that can be used both in the car body repair field as well as in the industrial one so to ensure an excellent welding quality in very high-productive fields.

### MAIN FEATURES

- Fully water-cooled "C"-type gun providing a force of 450daN at 8 bar.
- The welding guns are connected to the machine through two extra-flexible water-cooled cables 2400 mm long.
- Water-cooling system on board the machine.
- The machines are equipped with suspension arm and balancer for hanging the guns.
- Communication via USB port.
- TE760 welding control unit of industrial design.
  - Pro
  - Simplified programming by means of 9 keys and backlit graphic display.
  - Medium frequency inverter control with IGBT.
  - Storage of 150 welding programs; 4 of them recallable from the outside.
  - Up to 15 programmable parameters for each program.
  - Slope up, slope down, pulses, pre-weld, post-weld functions and adjustment of the welding times with 1 ms resolution.
  - Display of the welding current RMS and of the use percentage of the welding machine.
  - 2 operating modes: constant current and FIX.
  - Welding current limits and inverter use percentage.
  - Stepper function to compensate the electrodes wear with programmable curves.
  - Single and automatic cycle.
  - WELD and NON WELD function.
  - Self-adjustment at mains frequency 50/60 Hz.
  - Communication via USB port.
  - Selectable languages: Italian, English, French, German, Spanish, Swedish or Portuguese.
  - Possibility of upgrading the control unit Firmware.
  - Programs sequence.
  - Possibility of consulting welding tables.



### MANUFACTURING OF «CF» VERSIONS

Upon demand, the machine may be equipped with:

A fully water-cooled "X"-type gun item 8678/SK developing a force of 610 daN at 6 bar. (Version CF01)

A fully water-cooled "X"-type gun item 8677/SK developing a force of 240 daN at 8 bar. (Version CF02)

A completely water-cooled single-sided gun item 3581K. (Version CF03)

			3660E-tech	3670E-tech
Tensione di rete	Supply voltage	V	*400	*400
Frequenza di rete	Mains frequency	Hz	*50 / 60	*50 / 60
Protezione di rete (ritardati)	Mains protection (delayed)	A	32	40
Potenza nominale 50% ED	Nominal power 50% ED	kVA	25	25
Potenza massima di saldatura	Maximum welding power	kVA	125	180
Corrente secondaria massima	Maximum secondary current	A	9000	12000
Corrente termica 100%	Thermal current 100%	kA	1,25	1,25
Tensione a vuoto secondaria	No load secondary voltage	V	13,3	14,2
Tempo di saldatura	Weld time	s	0,01 ÷ 2	0,01 ÷ 2
Classe di protezione	Protection rating	IP	21	21
Peso	Weight	kg	155	155

\* Altre tensioni e frequenze a richiesta

\* Different voltages and frequencies on demand

## 3660E-tech | 3670E-tech

Die E-tech sind die neuen TECNA Schweiß-Systeme, geeignet für Endproduktionsanlagen.

Die Vielseitigkeit der Maschine gemeinsam mit den optimalen technischen Eigenschaften der Schweiß-Steuerung TE760 ergeben eine Maschine, die ihre Anwendung für Reparaturarbeiten im Karosseriebereich findet; sie ist auch im Industriebereich anwendbar, da sie die beste Schweißqualität in hochproduktiven Bereichen gewährleistet.

### TECHNISCHE EIGENSCHAFTEN

- Komplett wassergekühlte „C“ Zange, die eine Kraft von 450 daN bei 8 bar erzeugt.
- Die Schweißzangen sind an die Maschine durch 2 extra-flexible wassergekühlte Kabel L=2400 mm angeschlossen.
- Die Maschine ist auch mit integriertem Kühlsystem ausgestattet.
- Die Maschinen sind mit Galgen und Federzug für die Aufhängung der Zangen ausgestattet.
- Kommunikation mittels USB.
- Schweiß-Steuerung TE760 des Industriebereichs.
  - Einfache Programmierung über 9 Tasten und graphisches hinterleuchtetes Display.
  - Inverter-MF-Steuerung mit IGBT.
  - Speicherung von 150 Schweißprogrammen, davon bis zu 4 extern abrufbar.
  - Bis zu 15 programmierbare Parameter für jedes Programm.
  - Slope up, Slope down, Pulsen.
  - Vor-Schweißung, Nach-Schweißung und Einstellung der Schweißzeiten auf 1mS.
  - Anzeige "RMS" des Schweißstroms und des Nutzungsanteils der Maschine.
  - 2 Funktionsmodalitäten: Konstantstrom und FIX.
  - Schweißstromlimits und Nutzungsanteil des Inverters.
  - Stepperfunktion zur Verschleißkompensation der Elektroden mit programmierbaren Kurven.
  - Einzelpunkt und Automatik.
- SCHWEISSEN / NICHT SCHWEISSEN.
  - Automatische Einstellung der Netzfrequenz 50/60 Hz.
  - Wahl der Sprachen: Italienisch, Englisch, Französisch, Deutsch, Spanisch, Schwedisch und Portugiesisch.
  - Möglichkeit Upgrading der Firmware der Steuerung.
  - Sequenz Programme.
  - Möglichkeit der graphischen Anzeige auf Display der Schweißzeit und des Schweißstroms.
  - Möglichkeit Beratung einiger Schweißstabellen.

### FERTIGUNG VON «CF» FÜHRUNGEN

Auf Anfrage kann die Maschine mit einer komplett:

Wassergekühlten „X“ Zange art. 8677/SK, die eine Kraft von 240 daN bei 8 bar erzeugt.(Versione CF01)

Wassergekühlten „X“ Zange art. 8678/SK, die eine Kraft von 610 daN bei 6 bar erzeugt.(Versione CF02)

Wassergekühlten Stosspunkter art. 3581Kausgestattet werden.(Versione CF03)



Art. | Item 8669/SK  
Pinza «C» | «C» Gun  
450 daN - 8 bar



Art. | Item 8678/SK  
Pinza «X» | «X» Gun  
610 daN - 6 bar

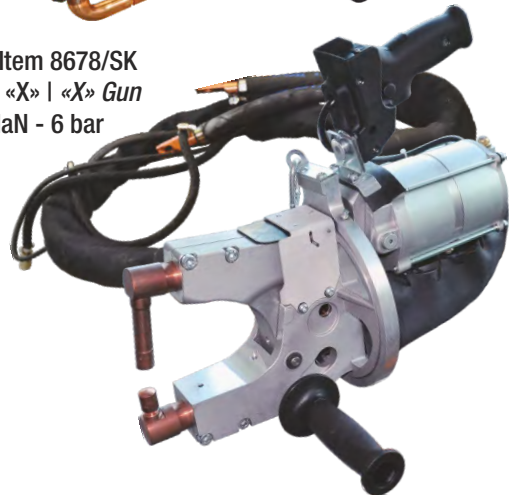

Art. | Item 8677/SK  
Pinza «X» | «X» Gun  
240 daN - 8 bar



Art. | Item 3581K  
Monopunto raffreddata | *water-cooled single-sided gun* |  
Wassergekühlten Stosspunkter.



Art. | Item 3581RK  
Monopunto raffreddata | *water-cooled single-sided gun* |  
Wassergekühlten Stosspunkter.



\*Andere Spannungen und Frequenzen auf Anfrage

SALDATRICE MEDIA FREQUENZA CON PINZA A FULCRO «X»  
MEDIUM FREQUENCY WELDING SYSTEM WITH «X» VERSION GUN  
MF-SCHWEISSMASCHINE MIT X-ZANGE

3660E-tech CF01 | 3670E-tech CF01

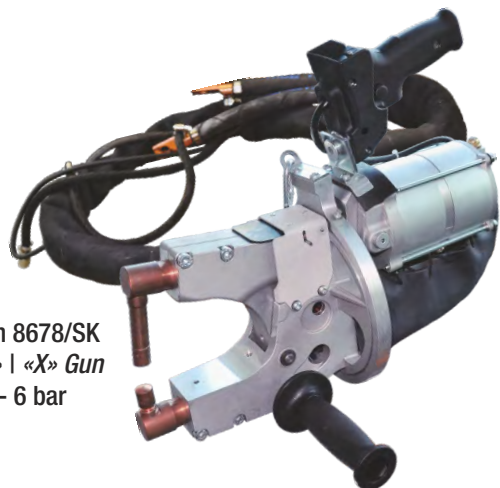

Art. | Item 8678/SK  
Pinza «X» | «X» Gun  
610 daN - 6 bar



3660E-tech CF02 | 3670E-tech CF02

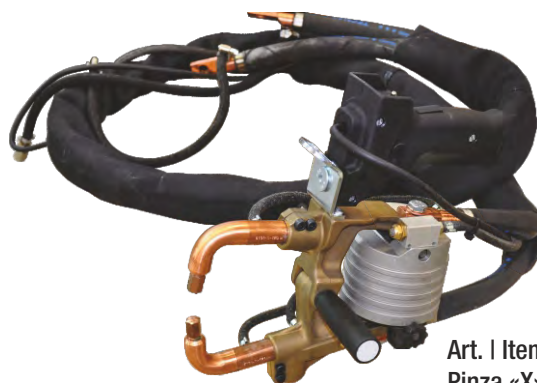

Art. | Item 8677/SK  
Pinza «X» | «X» Gun  
240 daN - 8 bar

**SALDATRICE MEDIA FREQUENZA CON PINZA A CORSOIO «C»**  
**MEDIUM FREQUENCY WELDING SYSTEM WITH «C» VERSION GUN**  
**MF-SCHWEISSMASCHINE MIT C-ZANGE**

**3660E-tech | 3670E-tech**

Art. | Item 8669/SK  
Pinza «C» | «C» Gun  
450 daN - 8 bar



**SALDATRICE MEDIA FREQUENZA CON MONOPUNTO RAFFREDDATA**  
**MEDIUM FREQUENCY WELDING SYSTEM WITH WATER-COOLED SINGLE-SIDED GUN**  
**MF-SCHWEISSMASCHINE MIT WASSERGEKÜHLTEN STOSSPUNKTER**

**3660E-tech CF03 | 3670E-tech CF03**



Art. | Item 3581K  
Monopunto raffreddata | *water-cooled single-sided gun* |  
Wassergekühlten Stosspunkter.

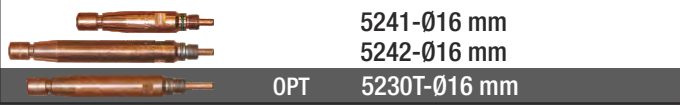

5241-Ø16 mm  
5242-Ø16 mm  
OPT 5230T-Ø16 mm

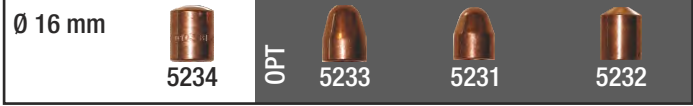

Ø 16 mm  
5234  
OPT 5233  
5231  
5232

**8685/W/S**

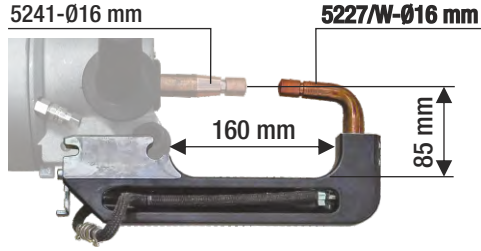

**8686/W/S**

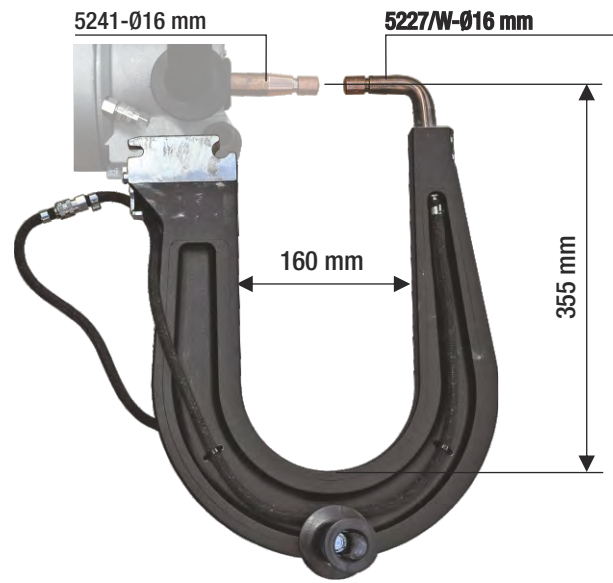

**8684/W/S**

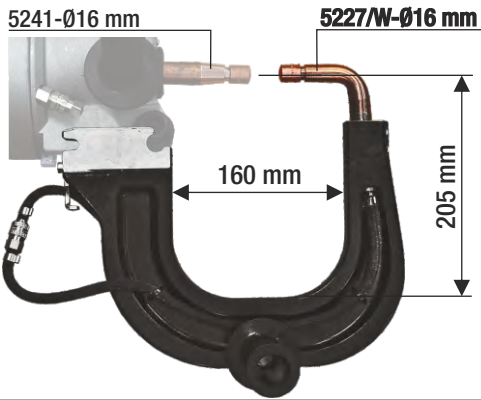

**8687/W/S**

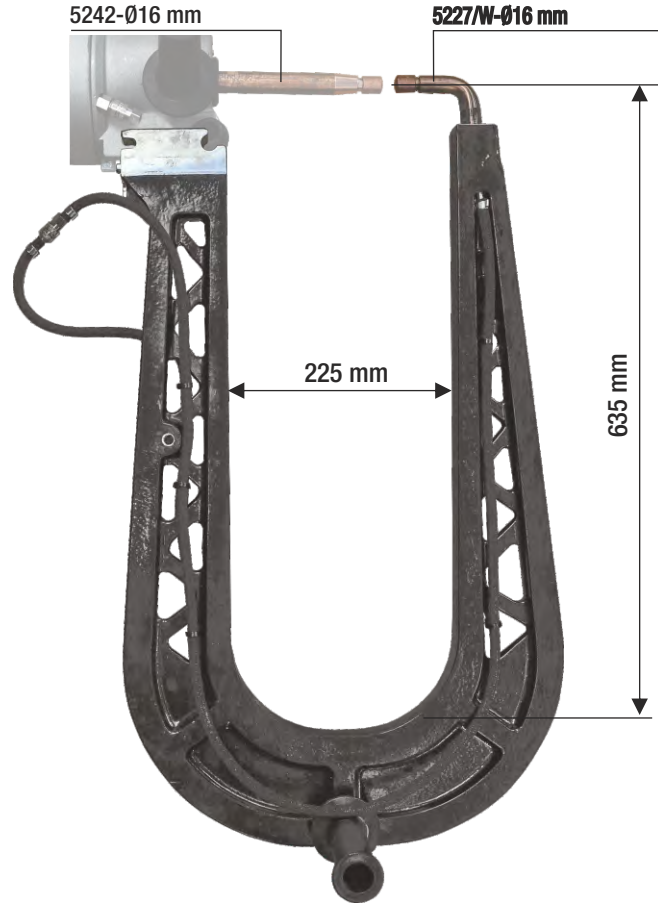

**8688/W/S**

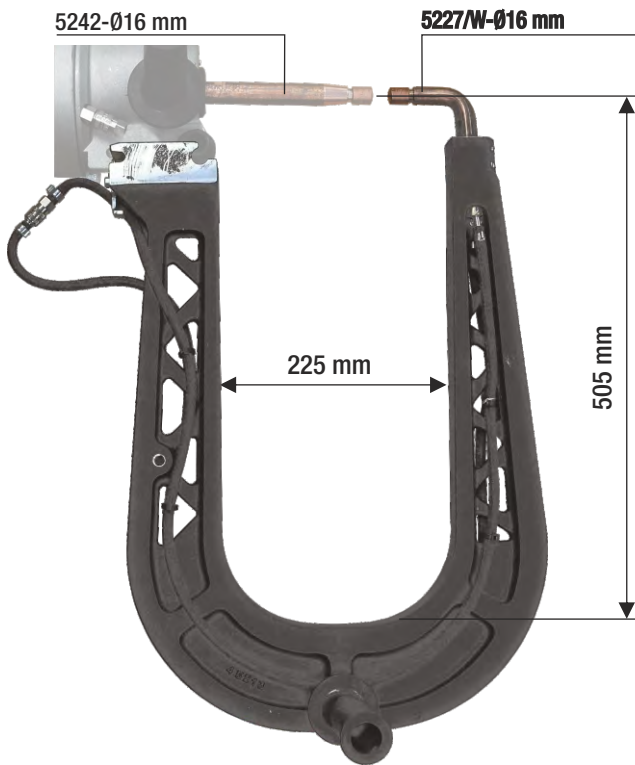

5220/W

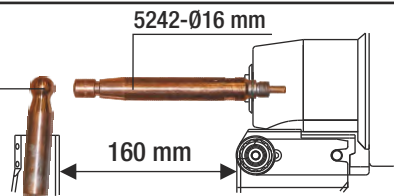

5243/W



5230T-Ø16 mm

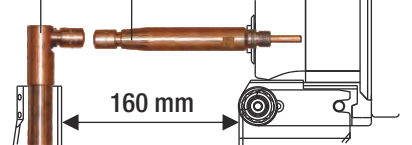

5223/W-Ø16 mm

5241-Ø16 mm

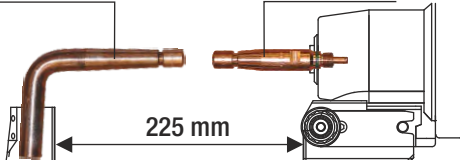

5244/W



5230T-Ø16 mm

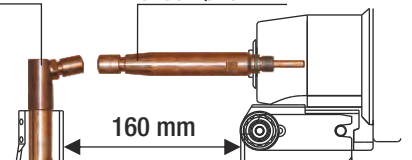

# 8677/SK

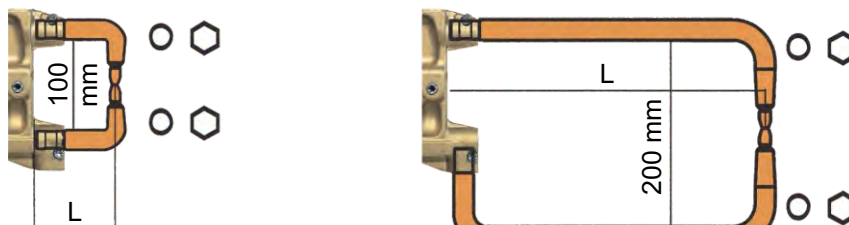

- 5127 L = 152 mm
- 5128 L = 232 mm
- 5129 L = 332 mm
- 5130 L = 483 mm

- 5137 L = 350 mm
- 5138 L = 450 mm



5210/C



5218/C

OPT

# 8678/SK

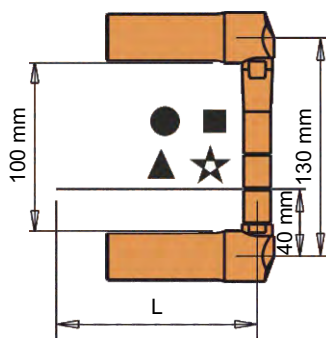

- 5260 L = 120 mm
- 5261 L = 155 mm
- 5262 L = 255 mm
- 5263 L = 355 mm
- 5264 L = 505 mm

Ø 16 mm

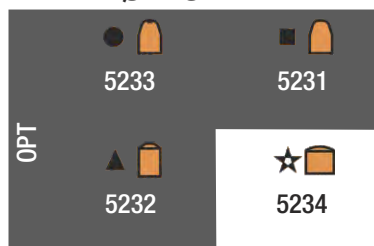

# 3581K



5218/C

Elettrodo punta sferica R=15mm confezione 12 pezzi  
 Round tip electrode R=15mm set of 12 pieces  
 Kugelförmige Spitzenelektrode R=15mm - 12 Stck. Packung



# 3581RK

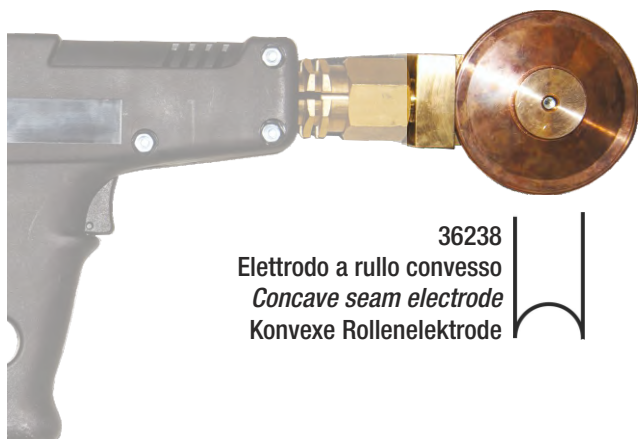

36238  
 Elettrodo a rullo convesso  
 Concave seam electrode  
 Konvexe Rollenelektrode

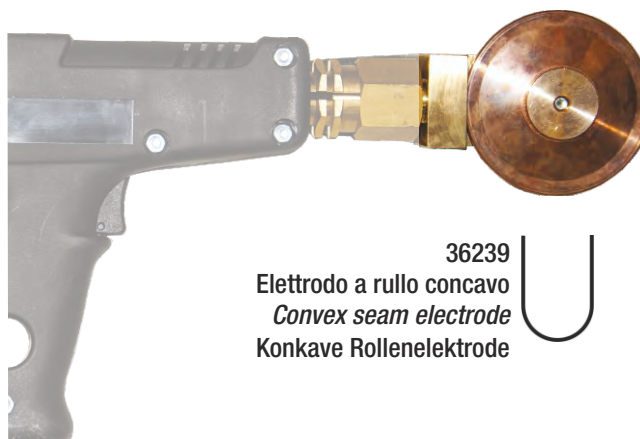

36239  
 Elettrodo a rullo concavo  
 Convex seam electrode  
 Konkave Rollenelektrode



**5235K**



**5234**  
n°36 elettrodi CAPS  
n°36 CAPS electrodes  
Nr. 36 ElektrodenKappen



**5233**  
n°16 elettrodi CAPS  
n°36 CAPS electrodes  
Nr. 36 ElektrodenKappen

**5233/C**



**5233/C**  
n°12 elettrodi CAPS  
n°12 CAPS electrodes  
Nr. 12 ElektrodenKappen

**5233**

**5234/C**



**5234/C**  
n°12 elettrodi CAPS  
n°12 CAPS electrodes  
Nr. 12 ElektrodenKappen

**5234**

La TECNA può variare senza preavviso alcuno i suoi prodotti - TECNA Specifications subject to change without notice. - TECNA behält sich das Recht vor, jederzeit Änderungen ohne Ankündigungen vorzunehmen.



World leader  
in Resistance Welding

**TECNA**<sup>®</sup>

Advanced Resistance Welding Systems and Balancers



**TECNA S.p.A.** | Via Meucci, 27 | 40024 | Castel S. Pietro Terme | Bologna (Italy)  
Ph. +39.051.6954400 | Fax +39.051.6954490  
<http://www.tecna.net> | E-mail: [sales@tecna.net](mailto:sales@tecna.net) | [vendite@tecna.net](mailto:vendite@tecna.net)