

**ELECTRIC TAPPING MACHINE
WITH BALANCED ARM
M2-M14 (M16)**

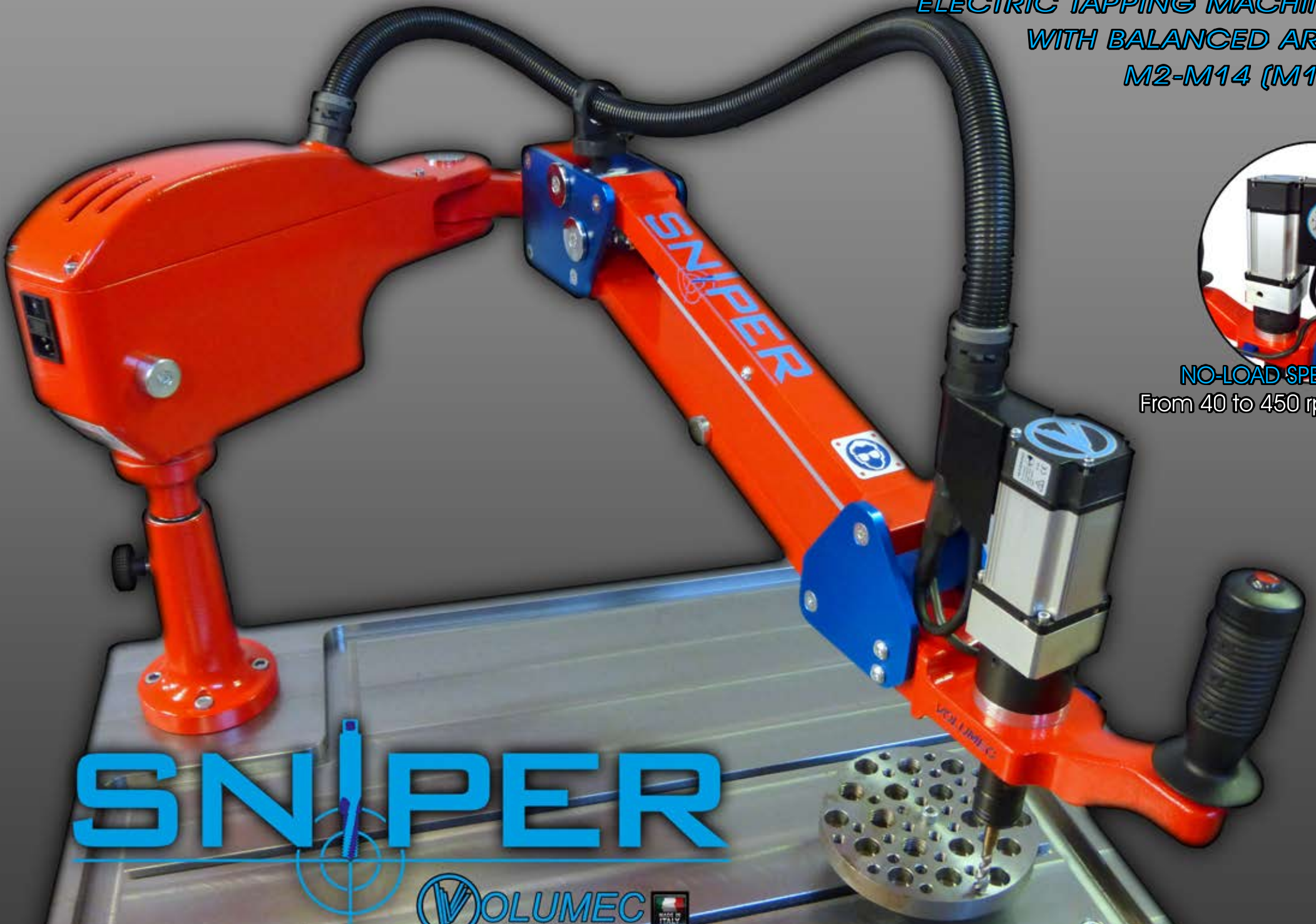

**NO-LOAD SPEED
From 40 to 450 rpm**



SNIPER

VOLUME C
mechanical innovations



SNIPER 400

Tapping capacity in Steel
M2 - M14 (M16 Al.)

No-load speed
40-450 rpm

Torque max.
39 Nm

Spindle
Ø 19 mm (GR1)

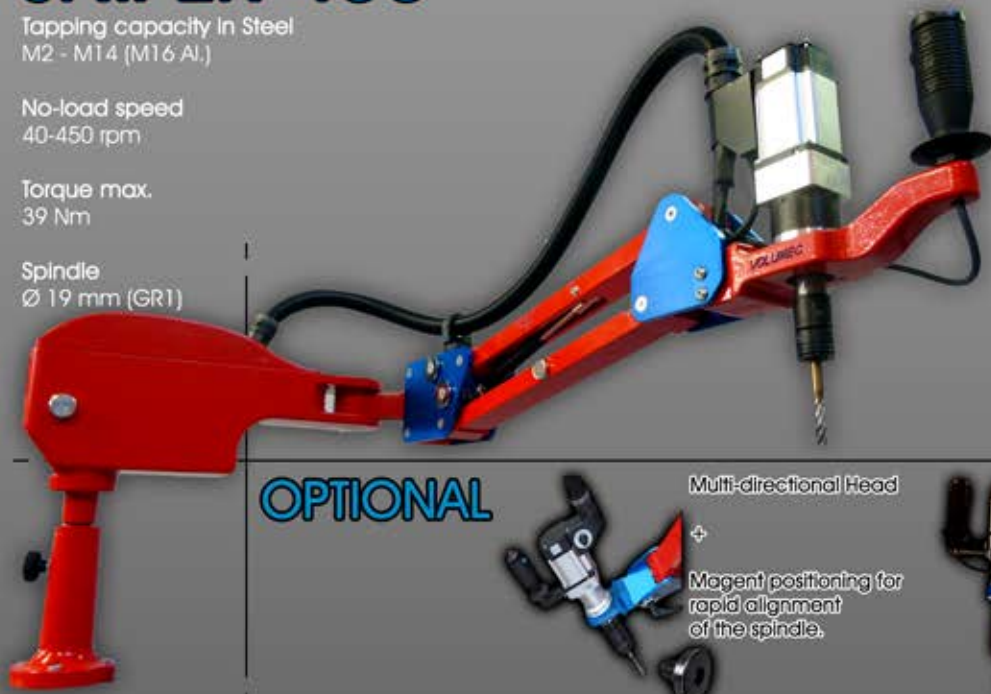

OPTIONAL



Multi-directional Head

Magent positioning for rapid alignment of the spindle.



Depth Sensor with automatic reverse

ACCESSORIES



Quick change bush with or without safety clutch
M2-M16 GR1

Die-holder for external threads



Work-table with T-slot
800 x 600 mm H = 830 mm

Thickness of the working plane 30 mm

Weight 150Kg



Bush with chuck adapter (1-13 mm) for drilling, countersinking, screwing



Trolley with wheels and brake
850 x 750 mm H= 870mm

Weight: 65 kg

MACHINE CHARACTERISTICS

- Articulated balanced arm made entirely of special aluminum, which guarantee high stability and a precise holes alignment.
- Electric Brushless Motor 400 W (220 V) complete integrated in the arm, with high performance, minimum noise and low electricity consumption.
- Large range of adjustment of tapping speed without the use of additional modules
 - Maximum reverse speed for the extraction of the tool
 - Articulated arm with adjustable balance
- Possibility to tap also blind hole with the quick change holders with safety and adjustable clutch to prevent tap breakage.

WORKING AREA

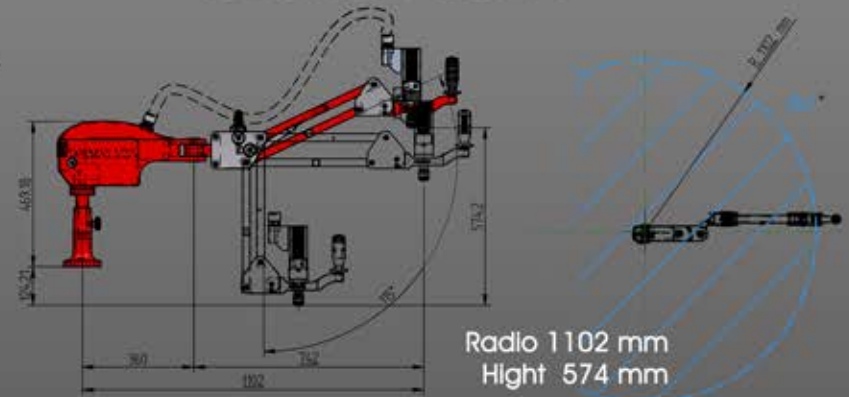

A.T.S s.r.l.

Via del Mangano n° 4/A
40023 Castel Guelfo (Bologna)
Tel: +39 0542 670427
Fax: +39 0542 670437
Email: info@atslamberti.com
www.atlamberti.com