

JT2 serie

- ▶ Double balanced articulated arm made entirely of aluminum, which guarantees a fast and precise holes alignment.
- ▶ Electric motor with Brushless technology 220v.
- ▶ Large range of adjustment of the speed processing according to the tool and the type of material. Double extraction speed (counterclockwise) set to 100% or 50% of Vmax.
- ▶ Joystick with control buttons for easy tool alignment and to speed up the execution of the work.
- ▶ Minimum noise and low electricity consumption.
- ▶ Rotational head can be set by the positioning magnet
- ▶ Balance and fluidity of movement guaranteed by gas springs and adjustable joints mounted on ball bearings.
- ▶ Possibility of tapping blind and open holes thanks to the adjustable clutch.
- ▶ Ray of work 1300mm.



Specification: Tapping Machines JT2

Model	Tapping capacity in Steel		Speed (rpm)	Workray (mm)	Weight (Kg)	Spindle
	Metric	Inches				
JT2000	M3 - M12	1/8"-1/2"	100-1000	1300	15	GR2
JT2150	M3 - M16	1/8"- 5/8"	50-500	1300	15	GR2
JT2500	M5 - M24	5/32"-7/8"	20-200	1300	16	GR2

Accessories



Bush for tapping with adjustable clutch
Tool holders for tap machine model M3 to M30 with and without friction, compasses, magnet positioning.



Depth sensor



Trolley
Detachable trolley for tap machines with a support for tapholders.
Size: 850x750x870h
Weight: 65Kg



Lubrication System
Automatic tap lubrication system.



Bush with chuck adapter from 1 to 10mm.



A.T.S. s.r.l.
Via del Mangano n° 4/A
40023 Castel Guelfo (Bologna)
Tel: +39 0542 670427
Fax: +39 0542 670437
Email: info@atslamberti.com
www.atlamberti.com

VOLUME
mechanical innovations



HIGH PRODUCTIVITY
LOW CONSUMPTION
LOW NOISE

JOYTAP
electrical tapping machine

ROTATIONAL HEAD

Rotational head to thread in any position.



Magnet positioning for rapid alignment of the spindle.

SPEED REGULATION

Quick speed setting according to the diameter of tapping



Multi speed

DEPTH SENSOR



Automatic reverse

RAY OF 1900MM

The triple articulated arm of the JT3 series allows you to work comfortably within a ray of 1900 mm.

JT3 serie

- ▶ Triple balanced articulated arm made entirely of aluminum, which guarantees a fast and precise holes alignment.
- ▶ Electric motor with Brushless technology 220v.
- ▶ Large range of adjustment of the speed processing according to the tool and the type of material. Double extraction speed (counterclockwise) set to 100% or 50% of Vmax.
- ▶ Joystick with control buttons for easy tool alignment and to speed up the execution of the work.
- ▶ Minimum noise and low electricity consumption.
- ▶ Rotational head which allows threading in any position. Standard feature.
- ▶ Magnet positioning for rapid alignment of the spindle.
- ▶ Balance and fluidity of movement guaranteed by gas springs and adjustable joints mounted on ball bearings.
- ▶ Possibility of tapping blind and open holes thanks to the adjustable clutch.

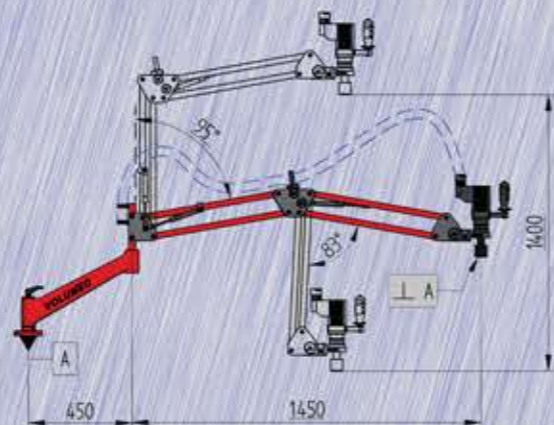
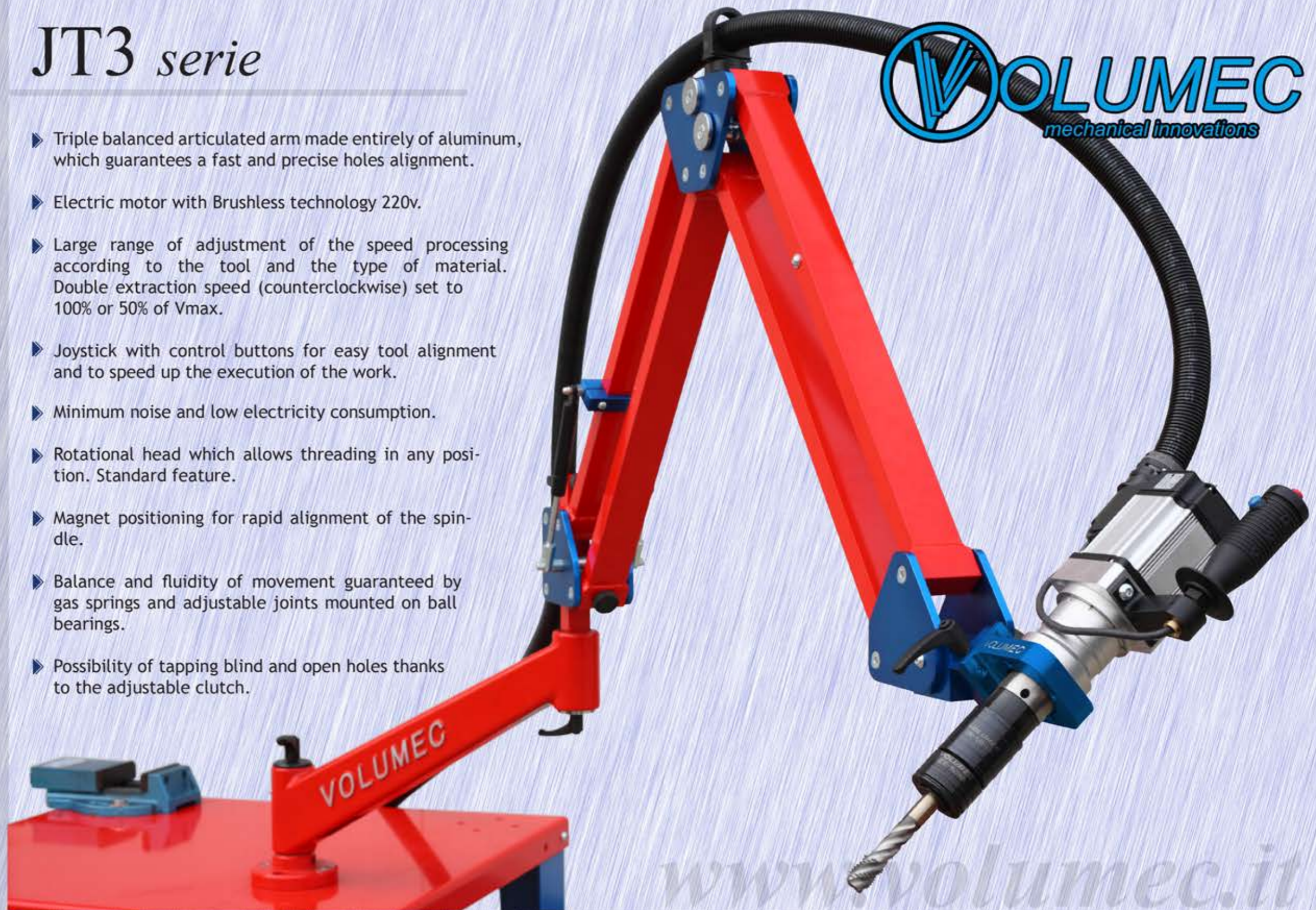

Specification: Tapping Machines JT3

Model	Tapping capacity in Steel		Speed (rpm)	Workray (mm)	Weight (Kg)	Spindle
	Metric	Inches				
JT3000	M2 - M12	0-1/2"	100-1000	1900	19	GR2
JT3150	M3 - M16	1/8"- 5/8"	50-500	1900	19	GR2
JT3500	M5 - M24	5/32"-7/8"	20-200	1900	20	GR2
JT3750 *	M8 - M36	5/16"- 1 3/8"	20-145	1900	25	GR3

*= fix head

www.volumec.it