

# FASTENERS PRESS 824

HIGH-PRECISION ASSEMBLY TECHNOLOGY



# TECHNICAL SPECIFICATIONS

## DATA AND STANDARD CONFIGURATION

TYPE	FASTENERS PRESS 824
Die depth	600 mm
Maximum die height	450 mm
Punch stroke	250 mm
Upper punch approach speed	60 mm / sec
Anti-crushing protection system	Safety system with electrical conductivity check
Maximum pressure	80 kN (8T)
Upper dead centre	10 mm – 100 mm
Drive system	Hydraulic
Repeatability of set pressure	±1%
Touch screen	7" PLC
Dimensions (mm)	H x L x D 2050 - 1100 - 950
Electrical specifications	380V 3.75 kW / three-phase + neutral
Gross weight	1100 Kg

# DIMENSIONS - FUNCTIONALITY

## TECHNICAL DESIGN AND OPERATIONAL BENEFITS

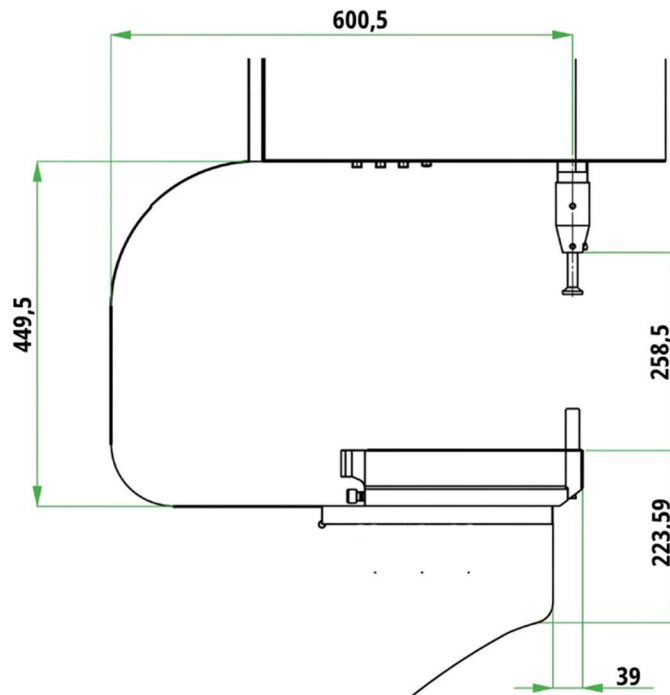

*Millimetre-precise dimensions of the press-fit groove for assessing the dimensions of the parts during the insertion stage*

## OPERATIONAL BENEFITS

- **Total safety:** integrated, comprehensive protection during operation, which eliminates any risk to the operator during the pressing cycle thanks to a safety system that monitors electrical conductivity.
- **Fast, optimised cycle times** to maximise line productivity and minimise downtime.
- **Intuitive ease of use:** immediate and precise adjustment of the working pressure and punch stroke directly from the regulator located next to the pressure gauge.
- **Minimal maintenance:** mechanical design intended to reduce the need for maintenance and ensure extremely high reliability.
- **Automation system designed for integration** with an automatic fastener feeding system (optional at the time of purchase).
- **Standard components:** all components fitted are top-of-the-range, reliable and readily available on the international market.

# CONSTRUCTION TECHNOLOGY

## CONTROLS, COMPONENTS AND ARCHITECTURE

### A) Laser pointer

Indicates the insertion point on the plate with red dot, making it easier to identify the exact position of the hole in the mould.

### B) Hydraulic cylinder

### C) Display

Digital display for piece counting, setting the number of fasteners per cycle, counting the number of work cycles performed, and controlling the punch lift.

### D) The control panel features

- Emergency stop button
- Operating light
- Key switch to override the automatic cycle operation system (this bypasses the machine's safety feature, which requires the pedal to be pressed once to move the punch into position and a second press to authorise the work cycle).

### E) Automatic feeder settings

Recommended for the production of large batches of the same type of insert, it significantly increases productivity – by at least three times – compared with manual processing times.

### F) Electrical panel

All the components are readily available.

### G) Quick adjustment of the pressing force, which remains visible throughout each work cycle

It is very quick and easy to make precise adjustments for machining hard or particularly soft materials, such as PC boards. It takes around 10 seconds to adjust the cutting force.

### H) Hydraulic system cooling system

### I) Automatic feeder (optional)

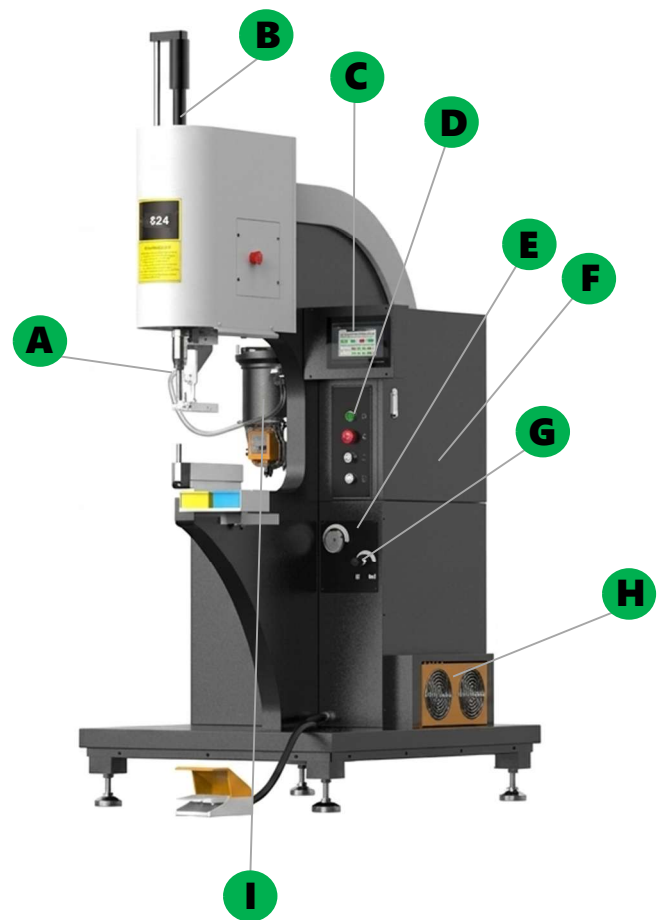

# EQUIPMENT AND ACCESSORIES

## TOOL KITS AND PRODUCTION CONFIGURATIONS



### **STANDARD TOOL KIT**

Set of dies (one per type):

Self-clinching nuts M3 - M4 - M5 - M6 - M8

Self-clinching studs M3 - M4 - M5 - M6 - M8

Self-clinching spacers M3 (d.4,2) - M3 (d.5,4) M4/M5(d.7,2)

Punches: N° 2, one narrow profile and one wide profile

Set of allen keys from 0,5 mm to 10 mm

N° 1 Set of punch safety springs

N° 2 toolbox opening keys



### **4-POSITION MANUAL TURRET (OPTIONAL)**

It allows four different dies to be fitted to the press at the same time. This accessory optimises processing time, enabling the operator to quickly select the required die by simply rotating the base, thereby eliminating the need for manual replacement.



### **AUTOMATIC FEEDER (OPTIONAL)**

The press is designed to accommodate an automatic feeder, a solution recommended for high-volume mass production. The use of the automatic system significantly increases productivity compared with the manual cycle, reducing cycle times depending on the type and size of the components. The system replaces the standard tool kit and is compatible with the full range of fasteners that can be used on the 824 model.

# AUTOMATIC FEEDING

## PROCESS OPTIMISATION AND PRODUCTIVITY



### **Automatic nuts feeding kit**

Available on request for:

- M3 nut (Ø 4,2 mm)
- M4 nut (Ø 5,4 mm)
- M5 nut
- M6 nut

### **Automatic studs feeding kit**

Available on request for:

- M3 Threaded stud (L max 20 mm)
- M4 Threaded stud (L max 20 mm)
- M5 Threaded stud (L max 20 mm)
- M6 Threaded stud (L max 20 mm)

### **Automatic spacers feeding kit**

Available on request for:

- M3 spacer (Ø 4,2 mm | L max 12 mm)
- M3 spacer (Ø 5,4 mm | L max 12 mm)
- M4/M5 spacer (Ø 7,2 mm | L max 12 mm)



### **Motorised support bench**

An adjustable, modular motorised bench, fitted with a wheeled movement system. The design ensures maximum operational flexibility, allowing the accessory to be quickly locked into position or completely removed, depending on the machining requirements.